

Cuisinart®

INSTRUCTION AND RECIPE BOOKLET



Frozen Yogurt-Sorbet & Ice Cream Maker

ICE-30C Series

For your safety and continued enjoyment of this product, always read the instruction book carefully before using.

IMPORTANT SAFEGUARDS

When using an electrical appliance, basic safety precautions should always be followed to reduce the risk of fire, electric shock, and/or injury, including the following:

1. READ ALL INSTRUCTIONS BEFORE USING.

- To protect against risk of electric shock, do not place cord, plug, or base of appliance in water or any other liquid.
- Close supervision is necessary when any appliance is used by or near children.
- Always unplug from outlet when not in use, before putting on or taking off parts, and before cleaning.
- Avoid contact with moving parts. Keep hands, hair, clothing, as well as spatulas and other utensils away during operation to reduce the risk of injury and/or damage to the appliance.
- Do not operate any appliance with a damaged cord or plug, or after the appliance malfunctions, or is dropped or damaged in any manner. Return the appliance to the nearest Cuisinart Repair Center for examination, repair, electrical or mechanical adjustment.
- The use of attachments not recommended by Cuisinart may cause fire, electric shock or risk of injuries.
- Do not use outdoors.
- Do not let cord hang over edge of table or counter, or touch hot surfaces.
- Keep hands and utensils out of freezer bowl while in use to reduce the risk of injury to persons or to the appliance itself. **DO NOT USE SHARP OBJECTS OR UTENSILS INSIDE THE FREEZER BOWL!** Sharp objects will scratch and damage the inside of the freezer bowl. A rubber spatula or wooden spoon may be used when the appliance is in the OFF position.
- This appliance is for household use. Any servicing other than cleaning and user maintenance should be done only by authorized Cuisinart Repair Personnel.
- Do not use the freezer bowl on flames, hot plates or stoves. Do not expose to heat source. Do not wash in dishwasher; doing so may cause risk of fire, electric shock or injury.

TABLE OF CONTENTS

Important Safeguards.....	2
Features and Benefits	2
Before Using for the First Time.....	3

Freezing Time & Bowl Preparation.....	3
Making Frozen Desserts or Drinks.....	3
Adding Ingredients	4
Safety Features	4
Cleaning and Storage.....	4
Recipe Tips	4
Ice Cream Serving Suggestions.....	5
Recipes.....	6
Warranty	16

SAVE THESE INSTRUCTIONS FOR HOUSEHOLD USE ONLY

NOTICE

IMPORTANT SAFEGUARD

Do not operate your appliance in an appliance garage or under a wall cabinet. When storing in an appliance garage always unplug the unit from the electric outlet. Not doing so could create a risk of fire, especially if the appliance touches the walls of the garage or the door touches the unit as it closes.

This appliance has a polarized plug (one blade is wider than the other). To reduce the risk of electric shock, this plug will fit in a polarized outlet only one way. If the plug does not fit fully in the outlet, reverse the plug. If it still does not fit, contact a qualified electrician. Do not attempt to defeat this safety feature.

CAUTION

This appliance is for household use. Any servicing other than cleaning and user maintenance should be performed by an authorized service representative.

- Do not immerse base in water.
- To reduce the risk of fire or electric shock, do not disassemble the base. Note: the base does not contain any user-serviceable parts.
- Repairs should be made only by authorized personnel.
- Check voltage to be sure that the voltage indicated on the name plate agrees with your voltage.
- Never clean with scouring powders or hard implements.

WARRANTY

The appliance is for 120 volt only and should not be used with a converter.

FEATURES AND BENEFITS

1. Ingredient Spout

Pour recipe ingredients through the spout. Also use to add ingredients, like chips or nuts, without interrupting the freezing cycle.

2. Easy-lock Lid

Transparent to let you watch the freezing process as it progresses. Lid is designed to easily lock to the base.

3. Mixing Arm

Mixes and aerates ingredients in freezer bowl to create frozen dessert or drink.

4. Freezer Bowl

Contains cooling liquid within a double insulated wall to create fast and even freezing. Double wall keeps the bowl cool and at an even temperature.

5. Base

Contains heavy-duty motor strong enough to handle ice cream, frozen yogurt, sherbet, sorbet, and frozen drinks.

6. On/Off Dial

7. Rubber Feet (not shown)

Nonslip feet keep base stationary during use.

8. Cord Storage (not shown)

Unused cord is easily pushed into the base to keep counters neat and safe.

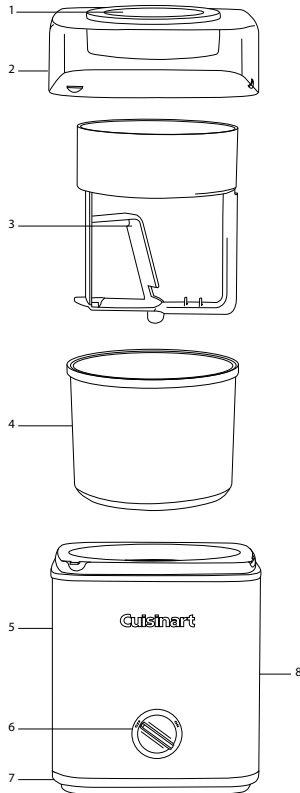

BEFORE USING FOR THE FIRST TIME

DO NOT immerse the motor base in water. Wipe it with a moist cloth. Wash the lid, freezer bowl and mixing arm in warm soapy water to remove any dust or residue from the manufacturing and shipping process. DO NOT clean any of the parts with abrasive cleaners or hard implements.

FREEZING TIME AND BOWL PREPARATION

The freezer bowl must be completely frozen before you begin your recipe. The length of time needed to reach the frozen state depends on how cold your freezer is. For the most convenient frozen desserts and drinks, leave your freezer bowl in the freezer at all times. You can take it out any time for immediate use. In general, freezing time is between 6 hours and 22 hours. To determine whether the bowl is completely frozen, shake it. If you do not hear liquid moving, the cooling liquid is frozen. Before freezing, wash and dry the bowl. Wrap it in a plastic bag to prevent freezer burn. We recommend that you place the freezer bowl in the back of your freezer where it is coldest.

Reminder: Your freezer should be set to 0°F (-18°C) to ensure proper freezing of all foods.

MAKING FROZEN DESSERTS OR DRINKS

1. Use Cuisinart's recipes from the pages that follow, or use your own recipe, making sure it yields 2 quarts or less. Do not fill the freezer bowl higher than 1/2" (1 cm) from the top. The ingredients will increase in volume during the freezing process. For best results, prepare ingredients in a container from which it is easy to pour.
2. Remove the freezer bowl from the freezer. (Remove plastic bag if you have wrapped freezer bowl.) Place freezer bowl on the centre of the base.
NOTE: Bowl will begin to defrost quickly once it has been removed from freezer. Use it immediately after removing from freezer.

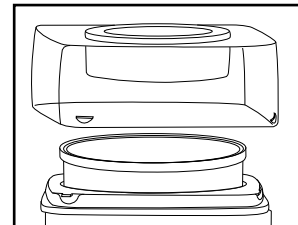

3. Place mixing arm in freezer bowl. Arm does not fit tightly. It just rests in the centre of the bowl, with the circle side facing up.

-
- Place lid on base. Easy-lock lid mechanism allows lid to rest on base in multiple positions (see diagram).
 - Turn the On/Off switch to ON position. Freezer bowl will begin to turn.
 - Immediately pour ingredients through ingredient spout.
 - Frozen desserts or drinks will be done in 25–35 minutes. The time will depend on the recipe and volume of the dessert or drink you are making. When the mixture has thickened to your liking, it is done. If you desire a firmer consistency, transfer the dessert or drink to an airtight container and store in the freezer for two or more hours.

NOTE: Do not store frozen desserts or drinks in the freezer bowl. Desserts and drinks will stick to the side of the freezer bowl and may damage the bowl. Store only in a plastic airtight container.

ADDING INGREDIENTS

Ingredients such as chips and nuts should be added about 5 minutes before the recipe is complete. Once the dessert or drink has begun to thicken, add the ingredients through the ingredient spout. Nuts and other ingredients should be no larger than a chocolate chip.

SAFETY FEATURE

The Cuisinart® Pure Indulgence™ Frozen Yogurt–Ice Cream & Sorbet Maker is equipped with a safety feature that automatically stops the unit if the motor overheats. This may occur if the dessert or drink is extremely thick, if the unit has been running for an excessively long period of time, or if added ingredients (nuts, etc.) are in extremely large pieces. To reset the unit, turn the ON/OFF switch to the OFF position. Let the unit cool off. After a few minutes, you may turn the unit on again and continue making the dessert or drink.

CLEANING AND STORAGE

Cleaning

Clean the freezer bowl, mixing arm and lid in warm soapy water. **DO NOT PUT FREEZER BOWL IN THE DISHWASHER. DO NOT CLEAN WITH ABRASIVE CLEANSERS OR IMPLEMENTS.** Wipe motor base clean with damp cloth. Dry all parts thoroughly.

Storage

DO NOT put freezer bowl in freezer if bowl is wet. DO NOT store lid, mixing arm, or base in freezer. You may store the freezer bowl in the freezer for convenient, immediate use. Before freezing, wrap the bowl in a plastic bag to prevent freezer burn. Do not store frozen desserts or drinks in the freezer bowl in the freezer for more than 30 minutes at a time. Transfer frozen desserts or drinks to an airtight container for longer storage in the freezer.

Cleaning & Maintenance

Any other servicing should be performed by an authorized service representative.

RECIPE TIPS

The recipes that follow offer you a variety of options for delicious frozen drinks and desserts. You may create or use recipes of your own, as long as they yield no more than 2 quarts (1.9 litres).

Recipe Tips:

- Some recipes use precooked ingredients. For best results, the mixture should be chilled overnight before using. Or, chill the recipe over an ice bath, until it is completely cooled, before using.
- To make an ice bath, fill a large container with ice and water. Place saucepan or other container into the ice bath. Cool pre cooked ingredients completely.
- Prior to freezing, most recipes may be stored in the refrigerator for up to 3 days.
- You may substitute lower-fat creams (e.g. half-and-half) and milk (reduced fat or lowfat) for heavy cream and whole milk used in many recipes. However, keep in mind that the higher the fat content, the richer and creamier the result. Using lower-fat substitutes may change the taste, consistency and texture of the dessert. When substituting, be sure to use the same volume of the substitute as you would have used of the original item. For example, if the recipe calls for two cups (500 ml) of cream, use a total of two cups of the substitute [such as 1 cup (250 ml) cream, 1 cup (250 ml) whole milk].
- In recipes that use alcohol, add the alcohol during the last two minutes of the freezing process. Otherwise, the alcohol may impede the freezing process.

-
- When making sorbet, be sure to test the ripeness and sweetness of the fruit before you use it. The freezing process reduces the sweetness of the fruit so that it will taste less sweet than the recipe mixture. If the fruit tastes tart, add sugar to the recipe. If the fruit is very ripe or sweet, reduce the amount of sugar in the recipe.
 - When making more than one recipe at a time, be sure the freezer bowl is completely frozen before each use.
 - Make sure mixing arm and lid are in place before turning on machine.

Mix-Ins for Ice Cream

Turn any of the “plain” flavours of ice cream into something fun by adding up to 1 cup (250 ml) of any of the following [or a mixture of 2 or more totaling 1 cup (250 ml)]: chopped cookies, favourite candy bars, brownies, leftover cake, marshmallows, chocolate morsels, peanut butter morsels, butterscotch morsels, toasted nuts, etc. Ingredients should be added about 5 minutes before the recipe is complete. Once the dessert or drink has begun to thicken, add the ingredients through the ingredient spout. Nuts and other ingredients should be no larger than a chocolate chip.

ICE CREAM SERVING SUGGESTIONS

Ice Cream Terrine

You can make an ice cream terrine or loaf as a special way to serve your homemade ice cream, gelato, frozen yogurt, or sorbet. Simply line an 8-cup (9x5x3-inch) loaf pan with a large sheet of plastic wrap. Spoon frozen mixture into prepared pan, cover completely and freeze for at least 2 hours. If desired, frozen mixture can be layered with thin cookies or layers of cake about 1/4- to 1/2- inch thick. Remove from freezer and place in refrigerator for 20 to 30 minutes before serving to facilitate slicing. Slice with a sharp knife that has been dipped in hot water, then dried.

Ice Cream Pies

You can easily make an ice cream pie using any flavour of ice cream, frozen yogurt, or even sorbet. Begin with a cooled crust – traditional pastry or crumb (it can be placed in the freezer while you are mixing your filling). You can fill the crust directly or add a layer of syrup, chocolate (you can sprinkle the hot crust with chopped chocolate or chocolate chips – they will then melt and form a layer of chocolate candy) or nuts. Spoon your frozen mixture directly from the Cuisinart ICE-30BCC into the chilled crust. Freeze for 1 hour until the top is firm, then cover and freeze until needed. Remove from the freezer and place in the refrigerator for 30 minutes before serving so that it

will become soft enough to slice but will still hold its shape. Serve plain, or with additional toppings such as fresh fruit, fruit syrup, chocolate or caramel sauce, nuts, cherries, etc. Top with freshly whipped cream.

Ice Cream Sodas

Ice cream sodas are made with a flavouring syrup, soda, and a scoop of your favourite ice cream, frozen yogurt or sorbet. Place 2 tablespoons (30 ml) of syrup in the bottom of a large glass. Add chilled soda or seltzer to within 2 inches (5 cm) of the rim of the glass. Top with 1 large scoop of very firm ice cream, frozen yogurt or sorbet – trying to get the scoop to straddle the rim of the glass but also be partly submerged in the soda. If the ice cream is too deep into the soda it will cause it to overflow, and if it doesn't touch, it is not an ice cream soda. The ice cream soda can be topped off with a squirt of whipped cream. The possibilities are endless. You can do a traditional soda such as a Black-and-White (chocolate syrup, seltzer, vanilla ice cream) or use ginger ale with a scoop of fruit-flavoured sorbet – or a more exotic combination.

Medleys or Parfaits

Choose flavours and colours that complement each other, and layer in parfaits or arrange on plates using small scoops. For instance, a bowl of small scoops of Red Raspberry Gelato, Blueberry Cassis Gelato, Mango Gelato, and Green Tea Gelato will make a dramatic presentation. Or try a medley of jewel-toned sorbets, such as Pink Grapefruit, Blueberry, and Sweet Dark Cherry.

WARRANTY

LIMITED THREE-YEAR

WARRANTY

We warrant that this Cuisinart product will be free of defects in materials or workmanship under normal home use for 3 years from the date of original purchase. This warranty covers manufacturer's defects including mechanical and electrical defects. It does not cover damage from consumer abuse, unauthorized repairs or modifications, theft, misuse, or damage due to transportation or environmental conditions. Products with removed or altered identification numbers will not be covered.

This warranty is not available to retailers or other commercial purchasers or owners. If your Cuisinart product should prove to be defective within the warranty period, we will repair it or replace it if necessary. For warranty purposes, please register your product online at www.cuisinart.ca to facilitate verification of the date of original purchase and keep your original receipt for the duration of the limited warranty. This warranty excludes damage caused by accident, misuse or abuse, including damage caused by overheating, and it does not apply to scratches, stains, discolouration or other damage to external or internal surfaces that does not impair the functional utility of the product. This warranty also expressly excludes all incidental or consequential damages.

Your Cuisinart product has been manufactured to the strictest specifications and has been designed for use only in 120 volt outlets and only with authorized accessories and replacement parts. This warranty expressly excludes any defects or damages caused by attempted use of this unit with a converter, as well as use with accessories, replacement parts or repair service other than those authorized by Cuisinart.

If the appliance should become defective within the warranty period, do not return the appliance to the store. Please contact our Customer Service Centre:

Toll-free phone number:
1-800-472-7606

Address:
Cuisinart Canada
100 Conair Parkway
Woodbridge, ON L4H 0L2

Email:
consumer_Canada@conair.com

Model: **ICE30C SERIES**

To facilitate the speed and accuracy of your return, please enclose:

- \$10.00 for shipping and handling of the product (cheque or money order)
 - Return address and phone number
 - Description of the product defect
 - Product date code*/copy of original proof of purchase
 - Any other information pertinent to the product's return
- * Product date code can be found on the underside of the base of the product. The product date code is a 4 or 5 digit number. Example, 90630 would designate year, month & day (2009, June 30th).

Note: We recommend you use a traceable, insured delivery service for added protection.

Cuisinart will not be held responsible for in-transit damage or for packages that are not delivered to us. To order replacement parts or accessories, call our Customer Service Centre at 1-800-472-7606. For more information, please visit our website at www.cuisinart.ca.

Cuisinart®



Food
Processors



Juicers



Coffeemakers



Cookware



Tools and
Gadgets

Cuisinart offers an extensive assortment of top quality products to make life in the kitchen easier than ever.
Try some of our other countertop appliances, cookware, tools and gadgets.

www.cuisinart.ca

©2017 Cuisinart Canada

100 Conair Parkway,
Woodbridge, ON L4H 0L2

Consumer Call Centre E-mail: |
Consumer_Canada@Conair.com

Printed in China

17CC18054

IB-5611-CAN-D

Trademarks or service marks referred to
herein are the trademarks or service marks
of their respective owners.