

Cuisinart™



**Cuisinart Supreme Grind™
Automatic Burr Mill**

DBM-8C

For your safety and continued enjoyment of this product, always read the instruction book carefully before using.

INTRODUCTION

Whatever your taste – automatic drip, espresso, or French press – you're about to experience a new level of taste! The Cuisinart Supreme Grind™ Automatic Burr Mill releases the maximum flavour and aroma from your favourite whole coffee beans. Simply select a grind setting and number of cups, and with the touch of a button, the Cuisinart Supreme Grind™ Automatic Burr Mill grinds just the right amount of coffee, then shuts off automatically. Get ready to experience the freshest, most flavourful coffee, with Cuisinart!

IMPORTANT SAFEGUARDS

When using electrical appliances, basic safety precautions should always be followed, including the following:

1. **READ ALL INSTRUCTIONS.**
2. **Unplug from outlet when not in use, before putting on or taking off parts, before removing coffee and before cleaning.**
3. To protect against risk of electrical shock, do not immerse cord, plug or grinder in water or other liquid.
4. Close supervision is necessary when any appliance is used by or near children.
5. Avoid contacting moving parts.
6. Do not operate any appliance with a damaged cord or plug, or after the appliance malfunctions, or is dropped or damaged in any manner. Return appliance to the nearest authorized Cuisinart service facility for examination, repair, or mechanical or electrical adjustment.
7. The use of attachments not recommended or sold by Cuisinart may cause fire, electrical shock, or risk of injury.
8. Do not use outdoors.
9. Do not let cord hang over edge of table or counter, or touch hot surfaces.
10. Before using, check hopper for presence of foreign objects.
11. Use this appliance to grind roasted coffee beans only. Grinding other substances, such as nuts, spices or unroasted beans, may dull the blade and cause poor grinding or injury.
12. Do not use appliance for other than intended use.
13. Do not place this appliance on or near a hot gas or electric burner, or in a heated oven.
14. **CAUTION:** Do not operate your appliance in an appliance garage or under a wall cabinet. When storing any appliance in an appliance garage always unplug the unit from the electrical outlet. Be sure the appliance does not touch the interior wall of the appliance garage, and the door does not touch the unit as it closes. Contact could cause the unit to turn ON, creating a risk of fire.

SAVE THESE INSTRUCTIONS FOR HOUSEHOLD USE ONLY

NOTICE:

This appliance has a polarized plug (one blade is wider than the other). To reduce the risk of electric shock, this plug will fit in a polarized outlet only one way. If the plug does not fit fully in the outlet, reverse the plug. If it still does not fit, contact a qualified electrician. Do not modify the plug in any way.

OPERATING INSTRUCTIONS:

1. Remove Bean Hopper lid.
2. Fill Bean Hopper to top, making sure that the lid closes securely. [Max fill is 8 ounces (227 g)].
3. Plug Cord into outlet.
4. Set Grind Selector. Note: Use coarse grind for percolator/ French press, medium grind for automatic drip, and fine grind for espresso.
5. Position Slide Dial to desired number of cups: 4 - 18. (590 ml - 2.6 L) Take into account that, based on personal preference, you can make your coffee stronger or weaker by adjusting cup selection.
6. Press and release Power Bar to begin grinding.
Please note: A safety feature of the grinder does not allow it to operate unless the hopper and grind chamber are properly in place.
7. Grinding will automatically stop upon completion.
8. To manually stop the operation, slide the Slide Dial all the way to the left to the "OFF" position and the unit will stop. To restart, repeat steps 5 & 6 above.
9. Remove Grind Chamber, make coffee, and enjoy!

- | | |
|-------------------------------------|-----------------------------------|
| 1. Hopper Lid | 7. Housing Base |
| 2. Bean Hopper | 8. Grind Chamber |
| 3. Burr Grinding Plates (not shown) | 9. Grind Release Area (not shown) |
| 4. Grind Selector | 10. Cord Storage |
| 5. Power Bar | 11. BPA Free (not shown) |
| 6. Slide Dial | |

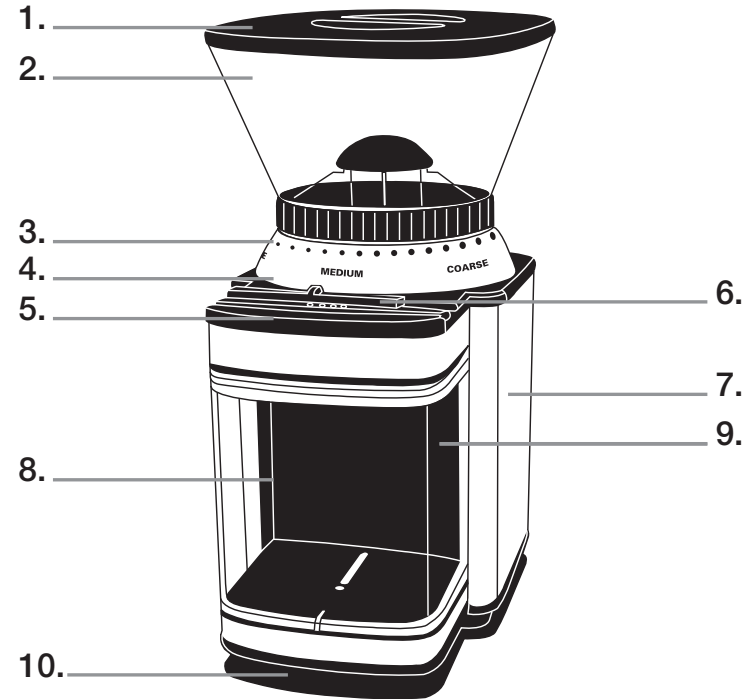

GRINDING TIMES:

Your Cuisinart Supreme Grind™ Automatic Burr Mill is fully automatic. There are 6 settings per grind type, and the grind chamber holds enough ground coffee for up to 32 cups (4.7 L). The unit is set for medium grind settings, which takes approximately 40 seconds to grind coffee for 12 cups (1.8 L), and approximately 55 seconds 18 cups (2.6 L).

When choosing fine settings, you may need to set the cup selector at a higher number of cups to get the desired amount of coffee, as fine grinds are very compact. The opposite is true for coarse settings. You may need to set the cup selector at a lower number of cups to get the desired amount of coffee, as coarse grinds are very loose. To determine the right grind consistencies and quantities, experiment with different grinds and coffee types to suit your taste.

CLEANING, STORAGE AND MAINTENANCE:

1. Be sure that grinder plug has been removed from outlet.
2. To remove the bean hopper, turn counterclockwise until it can be lifted from the housing base. To reattach, align bean hopper with opening on the housing base and turn clockwise. The bean hopper will return to the Grind Selection position when you hear a clicking sound.
3. Never immerse the grinder base unit in water or other liquid. To clean, wipe with wet cloth and use cleaning brush to clean grind release area.
4. Store excess cord by wrapping cord around the tabs provided under the base of the unit.
5. Any other servicing of this product should be performed by an authorized service representative.

WARRANTY LIMITED THREE-YEAR WARRANTY

We warrant that this Cuisinart product will be free of defects in materials or workmanship under normal home use for 3-years from the date of original purchase. This warranty covers manufacturer's defects including mechanical and electrical defects. It does not cover damage from consumer abuse, unauthorized repairs or modifications, theft, misuse, or damage due to transportation or environmental conditions. Products with removed or altered identification numbers will not be covered.

This warranty is not available to retailers or other commercial purchasers or owners. If your Cuisinart product should prove to be defective within the warranty period, we will repair it or replace it if necessary. For warranty purposes, please register your product online at www.cuisinart.ca to facilitate verification of the date of original purchase and keep your original receipt for the duration of the limited warranty. This warranty excludes damage caused by accident, misuse or abuse, including damage caused by overheating, and it does not apply to scratches, stains, discolouration or other damage to external or internal surfaces that does not impair the functional utility of the product. This warranty also expressly excludes all incidental or consequential damages.

Your Cuisinart product has been manufactured to the strictest specifications and has been designed for use only in 120 volt outlets and only with authorized accessories and replacement parts. This warranty expressly excludes any defects or damages caused by attempted use of this unit with a converter, as well as use with accessories, replacement parts or repair service other than those authorized by Cuisinart.

If the appliance should become defective within the warranty period, do not return the appliance to the store. Please contact our Customer Service Centre:

Toll-free phone number:

1-800-472-7606

Address:

Cuisinart Canada 100 Conair Parkway Woodbridge, Ont. L4H 0L2

Email: consumer_Canada@conair.com

Model: DBM-8C

To facilitate the speed and accuracy of your return, please enclose:

- \$10.00 for shipping and handling of the product (cheque or money order)
- Return address and phone number
- Description of the product defect
- Product date code*/copy of original proof of purchase
- Any other information pertinent to the product's return

* Product date code can be found on the underside of the base of the product. The product date code is a 4 or 5 digit number. Example, 90630 would designate year, month & day (2009, June 30th). **Note:** We recommend you use a traceable, insured delivery service for added protection. Cuisinart will not be held responsible for in-transit damage or for packages that are not delivered to us.

To order replacement parts or accessories, call our Customer Service Centre at 1-800-472-7606. For more information, please visit our website at www.cuisinart.ca

©2012 Cuisinart Canada
100 Conair Parkway,
Woodbridge, Ontario L4H 0L2
Printed in China