

Cuisinart®

INSTRUCTION &
RECIPE BOOKLET



6-Slice Traditional Waffle Iron

WAF-6C

For your safety and continued enjoyment of this product, always read the instruction book carefully before using.

IMPORTANT SAFEGUARDS

When using an electrical appliance, basic safety precautions should always be followed, including the following:

1. **READ ALL INSTRUCTIONS.**
2. Do not touch hot surfaces. Use handles and knobs.
3. To protect against fire, electrical shock, and injury to persons, **DO NOT IMMERSER CORD, PLUG, OR UNIT** in water or other liquids.
4. Close supervision is necessary when any appliance is used by or near children.
5. Unplug from outlet when not in use and before cleaning. Allow to cool before putting on or taking off parts, and before cleaning appliance.
6. Do not operate any appliance with a damaged cord or plug, or after the appliance malfunctions or has been damaged in any manner. Return appliance to the nearest Cuisinart Authorized Service Facility for examination, repair, or adjustment.
7. The use of accessory attachments not recommended by Cuisinart may result in fire, electrical shock, or injury to persons.
8. Do not use outdoors.
9. Do not let power cord hang over edge of table or counter, or touch hot surfaces.
10. Do not place on or near a hot gas or electric burner, or in a heated oven.
11. Unplug the unit when finished baking waffles.
12. Do not use appliance for other than intended use.
13. Extreme caution must be used when moving an appliance containing hot oil or other hot liquids.
14. Always attach plug to appliance first; then plug cord into the wall outlet. To disconnect, turn control dial to OFF setting; then remove plug from wall outlet.

15. **WARNING:** TO REDUCE THE RISK OF FIRE OR ELECTRIC SHOCK, REPAIR SHOULD BE DONE ONLY BY AUTHORIZED PERSONNEL. DO NOT REMOVE THE BASE PANEL. NO USER SERVICEABLE PARTS ARE INSIDE.

SAVE THESE INSTRUCTIONS FOR HOUSEHOLD USE ONLY

SPECIAL CORD SET INSTRUCTIONS

A short power supply cord is provided to reduce the risks resulting from becoming entangled in or tripping over a longer cord.

Longer extension cords are available and may be used if care is exercised in their use.

If a long extension cord is used, the marked electrical rating of the extension cord should be at least as great as the electrical rating of the appliance. The longer cord should be arranged so that it will not drape over the countertop or tabletop where it can be pulled on by children or animals, or tripped over.

NOTICE:

This appliance has a polarized plug (one blade is wider than the other). To reduce the risk of electric shock, this plug will fit in a polarized outlet only one way. If the plug does not fit fully in the outlet, reverse the plug. If it still does not fit, contact a qualified electrician. Do not modify the plug in any way.

TABLE OF CONTENTS

Important Safeguards	Page 2
Introduction	Page 3
Parts and Features	Page 3
Before First Use	Page 3
Operating Instructions	Page 4
Cleaning and Care	Page 4
Storage	Page 5
Tips	Page 5
Suggested Toppings	Page 5
Recipes	Page 5
Warranty	Page 11

INTRODUCTION

Cuisinart has always had a flair for the dramatic, and your new 6-Slice Traditional Waffle Iron is one of the best examples yet! The look is solid – a cross between commercial and consumer, with brushed stainless steel that’s upscale and elegant. Smooth, flared sides add style and catch drips for easy cleanups. You’ll love the options that 6 browning settings provide, and the successful results that indicator lights and an audible tone guarantee. Your waffle iron bakes six waffles at once, so no one has to wait for fun family breakfasts or delightfully different desserts. Plates are nonstick, so just heat them up and get ready to enjoy Cuisinart at its best!

PARTS AND FEATURES

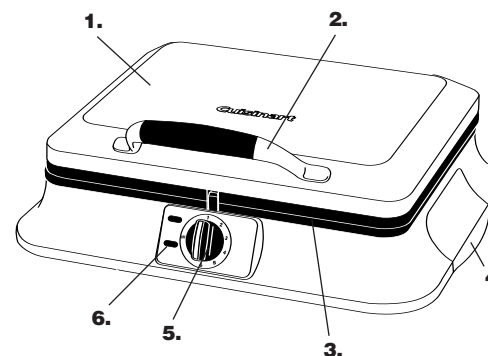

1. **Housing** – Elegant brushed stainless steel cover and base with embossed Cuisinart logo.
2. **Lid Handle** – Polished die-cast handle with cool touch grip. Locks down for baking and storing.
3. **Baking Plates** – Die-cast aluminum plates bake six traditional-style waffles.
4. **Base Handles** – Cool touch plastic will not become hot while baking.
5. **Control Dial** – Six adjustable browning settings and OFF position.
6. **Indicator Lights** – Red indicator light signals power on; green indicator light signals when waffle iron is ready to bake and waffles are cooked and ready to eat.
7. **Audible Signal (not shown)** – Signals when waffle iron is ready to bake and waffles are cooked and ready to eat.
8. **Storage (not shown)** – Cord wraps under base and unit stands on back end for storing.
9. **Rubber Feet (not shown)** – Feet keep unit steady and won’t mark countertop.

BEFORE THE FIRST USE

Remove all packaging and any promotional labels or stickers from your waffle iron. Be sure that all parts (listed above, **Parts and Features**) of your new waffle iron have been included before discarding any packaging materials. You may want to keep the box and packing materials for use at a later date.

Before using your Cuisinart® 6-Slice Traditional Waffle Iron for the first time, remove all protective paper and wrapping. Wipe housing and waffle plates with a damp cloth to remove any dust from the warehouse or shipping.

Note: This Cuisinart® 6-Slice Traditional Waffle Iron has been treated with a special nonstick coating. Before the first use, we suggest you season the grids with cooking spray or oil. If using oil, apply oil with a paper towel or pastry brush. You may find it helpful to repeat this process before each use of the waffle iron.

OPERATING INSTRUCTIONS

1. Place the closed waffle iron on a clean, flat surface where you intend to bake.
2. Plug the power cord in a standard electrical outlet.
3. Turn the control dial clockwise from the OFF position to the desired browning setting. Setting #1 for the lightest colour waffles and setting #6 for the darkest colour waffles. We recommend using setting #3 for golden brown waffles.

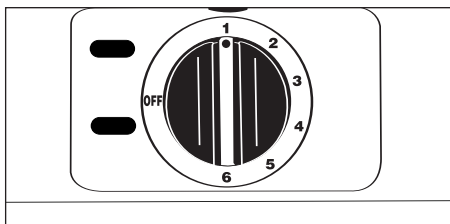

The red indicator light will turn on to signal power. Allow the waffle iron to preheat. When the waffle iron has reached desired temperature, the green indicator light will turn on and the audible tone will sound. You are now ready to begin baking.

Note: The first time you use your waffle iron it may have a slight odour and may smoke a bit. This is normal, and common to appliances with a nonstick surface.

4. Lift lid of waffle iron by grasping the handle and pushing back and up in one fluid motion. Lid will stay open at 105° position until you lower it.

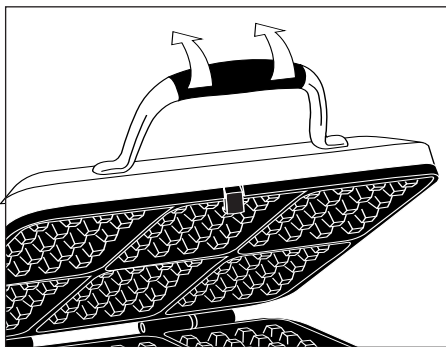

5. Pour batter onto the centre of the lower waffle grid. Use a heat-proof spatula to spread batter evenly over the grids. Close the lid. The waffle iron will automatically latch shut when you lower the lid. The green light will turn off but the red light will stay illuminated.
6. Baking time is determined by the browning level that you chose in Step 3. It may take up to 5 minutes to bake your waffle on setting #6.
7. When the waffles are ready to eat, the green light will turn on and the audible tone will sound. Remove waffles by gently loosening the edges with a heat-proof plastic spatula or wooden spatula. Never use metal utensils, as they will damage the nonstick coating.
8. When you are finished baking, turn the control dial counterclockwise to the OFF setting. The red indicator light will turn off. Unplug the power cord from the wall outlet. Allow the waffle iron to cool down completely before handling.

CLEANING AND CARE

Once you have finished baking, turn the control dial to the OFF position and remove plug from electrical outlet. Leave top lid open so grids begin to cool. Allow waffle iron to cool down completely before handling.

Never take your waffle iron apart for cleaning. Simply brush crumbs from grooves, and absorb any excess cooking oil by wiping with a dry cloth or paper towel.

You may also clean the grids by wiping with a damp cloth to prevent staining and sticking from batter or oil buildup. **Be certain grids have cooled completely before cleaning.** If batter adheres to plates, simply pour a little cooking oil onto the baked batter and let stand approximately 5 minutes, thus allowing it to soften for easy removal.

To clean exterior, wipe with a soft dry cloth. Never use an abrasive cleanser or harsh pad. **NEVER IMMERSE CORD, PLUG OR UNIT IN WATER OR OTHER LIQUID.**

STORAGE

Store with cord wrapped securely. For compact storage, stand waffle iron upright on back end with control panel facing up. The waffle iron has been designed with a special latching feature so lid stays closed during storage.

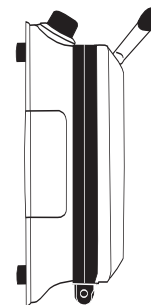

TIPS TO MAKE PERFECT WAFFLES

We recommend setting #3 or #4 for golden brown waffles, either from mix or homemade.

If you prefer crisper, darker waffles, increase the browning control.

For evenly filled waffles, pour the batter into the centre of the lower grid and spread out evenly to the edges. The entire lower grid should be filled.

We recommend using 1½ cups (375 mL) batter per waffle for most recipes.

Waffles are best when made to order, but pre-baked waffles may be kept warm in a 200° F (95°C) oven. Place in a baking pan or wrap in foil while in the oven. Waffles wrapped in foil may lose their crispiness.

Baked waffles may be frozen. Allow to cool completely; then place in plastic food storage bag. Use waxed paper to keep waffles separated. Reheat in toaster or toaster oven when ready to use.

SUGGESTED TOPPINGS

Maple syrup, fruit syrups
Warm fruit compote, fruit sauce
Fresh berries, chopped fruit
Chopped nuts
Powdered sugar
Whipped cream
Ice cream, sorbet
Chocolate sauce
Fruited yogurt

RECIPES

BASIC WAFFLES

Fresh, homemade waffles make breakfast a special occasion. Freeze the extras to use when time is scarce.

Makes 24 waffles

- 6 cups (1.5 L) all-purpose flour
- ¼ cup (50 mL) plus 2 tablespoons (30 mL) granulated sugar
- 3 tablespoons (45 mL) baking powder
- 1½ teaspoons (7 mL) baking soda
- 1½ teaspoons (7 mL) salt
- 5¼ cups (1.3 L) lowfat milk
- 1 cup (250 mL) plus 2 tablespoons (30 mL) vegetable oil
- 6 large eggs

Place ingredients in a large mixing bowl and combine until well blended and smooth. Let batter rest 5 minutes before using. Preheat your Cuisinart® Waffle Iron on setting #3.

When preheated, green indicator light will illuminate. Pour 2 cups (500 mL) batter evenly over the lower grid; spread batter using a heat-proof spatula to within ½ inch (1 cm) of the edge of the grid. Close lid of waffle iron – green indicator light will turn off. When green indicator light turns on again, waffle is ready. Open lid and carefully remove baked waffle. Repeat with remaining batter. For best results, serve immediately.

Nutritional information per waffle:
Calories 262 (44% from fat) • carb. 30g • pro. 7g
• fat 13g • sat. fat 2g • chol. • 57mg • sod. 372mg
• calc. 177mg • fiber 1g

CHOCOLATE BROWNIE WAFFLES

A treat for breakfast or dessert.

Makes 24 waffles

- 4 cups (1 L) all-purpose flour
- 1½ cups (375 mL) granulated sugar
- 1½ cups (325 mL) unsweetened cocoa powder
- 2 tablespoons (30 mL) baking powder
- 1 teaspoon (5 mL) baking soda
- 1 teaspoon (5 mL) salt
- 1 teaspoon (5 mL) cinnamon
- 4 cups (1 L) reduced-fat milk (may use evaporated fat-free milk)
- 4 large eggs
- 2 teaspoons (10 mL) vanilla extract

- 8 tablespoons (120 mL) unsalted butter, melted, cooled slightly**
1½ cups (325 mL) semi-sweet mini chocolate morsels
1 cup (250 mL) finely chopped walnuts or pecans

Place the flour, sugar, cocoa powder, baking powder, baking soda, salt, and cinnamon in a medium bowl; stir with a whisk to blend. Add the milk, eggs and vanilla. Stir with a whisk until well blended and smooth. Stir in melted butter. Let batter stand 5 minutes. Preheat Cuisinart® Waffle Iron on setting #4.

When preheated, green indicator light will illuminate. Stir chocolate morsels and chopped walnuts/pecans into batter. Pour 2 cups (500 mL) batter along centre of lower grid. Let batter spread out from centre slightly – for 5 to 10 seconds. Close lid of waffle iron – green indicator light will turn off. When green indicator light turns on again, waffle is ready. Remove waffle using a heat-proof plastic spatula. Repeat with remaining batter. For best results, serve immediately.

Nutritional analysis per waffle:
Calories 315 (44% from fat) • carb. 39g • pro. 7g
• fat 17g • sat. fat 8g • chol. 59mg • sod. 238mg
• calc. 73mg • fiber 3g

NUTTY WHEAT WAFFLES

Wholesome wheat flavour combines with crunchy nuts for a delicious breakfast, brunch or snack. Top with warm syrup or fruit compote.

Makes 30 waffles

- 4½ cups (1.125 L) all-purpose flour**
1½ cups (375 mL) whole wheat flour
¼ cup (50 mL) plus 2 tablespoons (30 mL) granulated sugar
3 tablespoons (45 mL) baking powder
1½ teaspoons (7 mL) salt
6 cups (1.5 L) reduced-fat milk
1 cup (250 mL) plus 2 tablespoons (30 mL) vegetable oil
6 large eggs
1½ cups (375 mL) finely chopped nuts, such as pecans, walnuts, almonds or hazelnuts

Place ingredients in a large mixing bowl and combine until well blended and smooth. Let batter rest 5 minutes before using. Preheat your Cuisinart® Waffle Iron on setting #3.

When preheated, green indicator light will illuminate. Pour 2 cups (500 mL) batter along the centre of the lower grid; spread batter using a heat-proof spatula to within ½ inch (1 cm) of the edge of the grid. Close lid of waffle iron – green indicator light will turn off. When green indicator light turns on again, waffle is ready. Open lid and carefully remove baked waffle. Repeat with remaining batter. For best results, serve immediately.

Nutritional information per waffle:
Calories 248 (55% from fat) • carb. 24g • pro. 7g
• fat 14g • sat. fat 2g • chol. 46mg • sod. 354mg
• calc. 74mg • fiber 2g

CINNAMON PECAN WAFFLES

Top these tasty waffles with warm maple syrup and fresh fruit.

Makes 30 waffles

- 6 tablespoons (90 mL) packed light brown sugar**
6 cups (1.5 L) all-purpose flour
3 tablespoons (45 mL) baking powder
4½ teaspoons (22 mL) ground cinnamon
1½ teaspoons (7 mL) baking soda
1½ teaspoons (7 mL) salt
5½ cups (1.375 L) reduced-fat milk
1 cup (250 mL) plus 2 tablespoons (30 mL) vegetable oil
6 large eggs, lightly beaten
3 cup (750 mL) chopped pecans

Crumble the brown sugar to remove all lumps and place in a medium mixing bowl with the flour, baking powder, cinnamon, baking soda, and salt. Combine the milk, oil and eggs; stir until blended and smooth. Add to the dry ingredients and stir until smooth. Stir in the chopped pecans. Let batter rest 5 minutes before using. Preheat your Cuisinart® Waffle Iron on setting #3.

When preheated, green indicator light will illuminate. Pour 2 cups (500 mL) batter along the centre of the lower grid; spread batter using a heatproof spatula to within ½ inch (1 cm) of the edge of the grid. Close lid of waffle iron – green indicator light will turn off. When green indicator light turns on again, waffle is ready. Open lid and carefully remove baked waffle. Repeat with remaining batter. For best results, serve immediately.

Nutritional Information per waffle:
Calories 283 (55% from fat) • carb. 26g • pro. 6g

• fat 18g • sat fat 2g • chol. 46mg • sod. 277mg
• calc. 71 mg • fiber 2g

APPLE WALNUT WAFFLES

Stir a teaspoon of cinnamon into maple syrup and warm to serve with Apple Walnut Waffles.

Makes 24 waffles

- ½ cup (125 mL) plus 1 tablespoon (15 mL) packed brown sugar**
4 cups (1 L) unbleached all-purpose flour
¾ cup (175 mL) whole wheat flour
¾ cup (175 mL) honey toasted wheat germ
3 tablespoons (45 mL) baking powder
1½ teaspoons (7 mL) salt
4½ cups (1.125 L) lowfat milk
6 large eggs, lightly beaten
1 cup (250 mL) vegetable oil
1½ teaspoons (7 mL) vanilla extract
3 cups (750 mL) finely diced or shredded apple [1 apple, 8 ounces (226 grams), peeled and cored]
1½ cups (375 mL) finely chopped walnuts

Crumble the brown sugar into a medium bowl to remove all lumps. Add the flours, wheat germ, baking powder and salt. Stir to blend. In another bowl, combine the milk, eggs, oil, and vanilla; stir with a whisk. Add the wet mixture to the dry mixture and stir until smooth. Stir in the apple and walnuts. Let batter rest 5 minutes before using. Preheat your Cuisinart® Waffle Iron on setting #3.

When preheated, green indicator light will illuminate. Pour 2 cups (500 mL) batter along the centre of the lower grid; spread batter using a heatproof spatula to within ½ inch (1 cm) of the edge of the grid. Close lid of waffle iron – green indicator light will turn off. When green indicator light turns on again, waffle is ready. Open lid and carefully remove baked waffle. Repeat with remaining batter. For best results, serve immediately.

Nutritional Information per waffle:
Calories 305 (48% from fat) • carb. 33g • pro. 8g
• fat 16g • sat fat 2g • chol. 57mg • sod. 319mg
• calc. 85mg • fiber 2g

BANANA WALNUT WAFFLES

Classic waffles for a weekend brunch.

Makes 24 waffles

- 4 cups (1 L) unbleached flour**
4 tablespoons (60 mL) granulated sugar
2 tablespoons (30 mL) baking soda
1 teaspoon (5 mL) salt
4 eggs, lightly beaten
¾ cup (175 mL) vegetable oil
2 cups (500 mL) vanilla yogurt, lowfat
1½ cups (375 mL) whole milk
2 cups (500 mL) banana, mashed
1 cup (250 mL) walnuts, chopped

Combine flour, sugar, baking soda, and salt in a mixing bowl and stir to combine. In a separate bowl whisk together the eggs and oil and stir into dry ingredients. Stir in yogurt and then milk until mixture resembles a smooth batter. Stir in banana and walnuts until incorporated. Let batter rest 5 minutes before using. Preheat your Cuisinart® Waffle Iron on setting #3.

When preheated, green indicator light will illuminate. Pour ½ cup (125 mL) of batter onto the centre of the lower grid. Allow batter to spread toward edges for 5 seconds. Close lid of waffle iron – green indicator light will turn off. When green indicator light turns on again, waffle is ready. Open lid and carefully remove baked waffle. Repeat with remaining batter. For best results, serve immediately.

Nutritional information per waffle:
Calories 223 (47% from fat) • carb. 25g • pro. 5g
• fat 12g • sat fat 2g • chol. 38mg • sod. 403mg
• calc. 63mg • fiber 1g

PUMPKIN WALNUT WAFFLES

For a change, you may substitute dried cranberries, raisins or even mini chocolate morsels for the walnuts.

Makes 18 waffles

- 3½ cups (875 mL) reduced-fat milk**
1½ cups (375 mL) solid pack pumpkin*
¾ cup (175 mL) vegetable oil
4 large eggs, lightly beaten
4½ cups (1.125 L) all-purpose flour
½ cup (125 mL) packed light brown sugar
2 tablespoons (30 mL) baking powder
1 teaspoon (5 mL) baking soda
2 teaspoons (10 mL) ground cinnamon
½ teaspoon (2 mL) salt
1½ cups (375 mL) chopped walnuts

Place the milk, pumpkin, oil, and eggs in a bowl. Stir until smooth; reserve. Place the flour in a large bowl. Crumble the brown sugar to remove the lumps; add to the flour along with the baking

powder, baking soda, cinnamon, and salt. Stir to blend. Add the liquid ingredients and whisk until smooth. Let batter rest 5 minutes before using. Preheat your Cuisinart® Waffle Iron on setting #3.

When preheated, green indicator light will illuminate. Stir walnuts into batter. Pour 2 cups (500 mL) batter along the centre of the lower grid. Allow batter to spread toward edges for 5 seconds. Close lid of waffle iron – green indicator light will turn off. When green indicator light turns on again, waffle is ready. Open lid and carefully remove baked waffle. Repeat with remaining batter. For best results, serve immediately.

*This is a little less than ½ of a 15-ounce (425 grams) can. Measure out ¾ cup (175 mL) of the remaining pumpkin and freeze to make these waffles at another time.

Nutritional Information per waffle:

*Calories 307 (51% from fat) • carb. 30g • pro. 8g
• fat 18g • sat fat 3g • chol. 51mg • sod. 269 mg
• calc. 86 mg • fiber 2g*

OATMEAL RAISIN WAFFLES

These waffles taste like an oatmeal raisin cookie. They are delicious when spread with apple butter.

Makes 18 waffles

- ¼ **cup (50 mL) plus 2 tablespoons (30 mL) packed light brown sugar**
- 3 cups (750 mL) all-purpose flour**
- 2 cups (500 mL) oatmeal (regular rolled oats, not quick oats)**
- 4 teaspoons (20 mL) ground cinnamon**
- 1 tablespoon (15 mL) baking powder**
- 2 teaspoons (10 mL) baking soda**
- 1 teaspoon (5 mL) salt**
- 3 cups (750 mL) buttermilk**
- 4 large eggs, lightly beaten**
- ¼ **cup (175 mL) vegetable oil (you may substitute unsalted butter, melted and cooled)**
- 1 teaspoon (5 mL) vanilla extract**
- 1½ cups (335 mL) raisins**

Crumble the brown sugar to remove any lumps and place in a medium bowl with flour, oatmeal, cinnamon, baking powder, baking soda, and salt. Stir to blend. Add buttermilk, eggs, oil, and vanilla. Stir until well blended and smooth. Stir in raisins. Let batter rest 5 minutes before using. Preheat your Cuisinart® Waffle Iron on setting #3.

When preheated, green indicator light will illuminate. Pour 2 cups (500 mL) batter along the centre of the lower grid; spread batter using a heatproof spatula to within ½ inch (1 cm) of the edge of the grid. Close lid of waffle iron – green indicator light will turn off. When green indicator light turns on again, waffle is ready. Open lid and remove baked waffle. Repeat with remaining batter. For best results, serve immediately.

Nutritional Information per waffle:

*Calories 278 (36% from fat) • carb. 38g • pro. 7g
• fat 11g • sat fat 2g • chol. 49mg • sod. 351mg
• calc. 77mg • fiber 2g*

CHOCOLATE BUTTERMILK WAFFLES

Great for breakfast, or try as a base for a hot fudge sundae.

Makes 24 waffles

- 3 cups (750 mL) unbleached flour**
- 1 cup (250 mL) unsweetened cocoa, sifted**
- ¼ **cup (50 mL) granulated sugar**
- ¼ **cup (50 mL) light brown sugar, packed**
- 4 teaspoons (20 mL) baking soda**
- 1 teaspoon (5 mL) salt**
- 4 eggs, lightly beaten**
- 2 teaspoons (10 mL) vanilla extract**
- ¾ **cup (175 mL) unsalted butter, melted**
- 2 cups (500 mL) buttermilk**
- 2 cups (500 mL) lowfat yogurt (plain or vanilla)**
- 2 cups (500 mL) semi sweet chocolate chips**

Place flour, cocoa, sugars, baking soda, and salt in a medium mixing bowl. Stir to combine. Stir in eggs, vanilla, butter, buttermilk, and yogurt successively, making sure each ingredient is incorporated well. Finally stir chocolate chips into batter. Let batter rest 5 minutes before using. Preheat your Cuisinart® Waffle Iron on setting #3.

When preheated, green indicator light will illuminate. Pour 2 cups (500 mL) of batter along the centre of the lower grid. Allow batter to spread toward edges for 5 seconds. Close lid of waffle iron – green indicator light will turn off. When green indicator light turns on again, waffle is ready. Open lid and carefully remove baked waffle. Repeat with remaining batter. For best results, serve immediately.

Nutritional information per waffle:

Calories 267 (43% from fat) • carb. 34g • pro. 5g

*• fat 13g • sat fat 7g • chol. 53 mg • sod. 327mg
• calc. 71mg • fiber 4g*

LEMON WAFFLES

Makes 30 waffles

- 3 cups (750 mL) unbleached flour**
- ¼ **cup (175 mL) granulated sugar**
- 4 teaspoons (20 mL) baking soda**
- 1 teaspoon (5 mL) salt**
- 4 eggs**
- 2 cups (500 mL) buttermilk**
- 2 teaspoons (10 mL) pure vanilla extract**
- ¼ **cup (50 mL) fresh lemon juice**
- 2 tablespoons (30 mL) lemon zest**
- ¾ **cup (175 mL) unsalted butter, melted**
- 2 cups (500 mL) vanilla yogurt**

Place flour, sugar, baking soda, and salt in mixing bowl and stir to combine. In a second bowl, whisk eggs, buttermilk, and vanilla until blended. Stir into dry ingredients. Stir in lemon juice and zest. Fold in melted butter and then vanilla yogurt with a rubber spatula or wooden spoon. Let batter rest a few minutes before using. Preheat your Cuisinart® Waffle Iron on setting #3.

When preheated, green indicator light will illuminate. Pour ½ cup (125 mL) of batter onto the centre of the lower grid. Allow batter to spread toward edges for 5 seconds. Close lid of waffle iron – green indicator light will turn off. When green indicator light turns on again, waffle is ready. Open lid and carefully remove baked waffle. Repeat with remaining batter. For best results, serve immediately.

Variations: For lemon ginger waffles, add 1 tablespoon (15 mL) of grated fresh ginger to the batter with the juice and zest. For lemon blueberry waffles, add 2 cups (500 mL) of blueberries to the batter as the last ingredient.

Nutritional information per waffle:

*Calories 135 (38% from fat) • carb. 18g • pro. 3g
• fat 6g • sat fat 3g • chol. 42mg • sod. 182mg
• calc. 52mg • fiber 0g*

SUPER MULTIGRAIN WAFFLES

These crispy waffles have a nice texture and pleasant flavour; you would never know they are good for you.

Makes 24 waffles

- 2 cups (500 mL) whole wheat flour**
- 1 cup (250 mL) unbleached flour**

- 1 cup (250 mL) old-fashioned oats**
- 2 teaspoons (10 mL) baking powder**
- 2 teaspoons (10 mL) baking soda**
- 1 teaspoon (5 mL) salt**
- 4 eggs, lightly beaten**
- 2 cups (500 mL) soy milk**
- ¼ **cup (50 mL) pure maple syrup**
- 2 teaspoons (10 mL) vanilla extract**
- ¼ **cup (175 mL) unsalted butter, melted**
- ¼ **cup (50 mL) flaxseed oil**
- 2 cups (500 mL) lowfat plain yogurt**
- 1 cup (250 mL) pecans or walnuts, finely chopped (optional)**

Place whole wheat flour, unbleached flour, oats, baking powder, baking soda, and salt in mixing bowl and stir to combine. In a separate bowl stir together eggs, soy milk, syrup, and vanilla and add to the dry ingredients. Stir in butter, flaxseed oil, and yogurt/cottage cheese. Finally stir chopped nuts into batter. Let batter rest 5 minutes before using. Preheat your Cuisinart® Waffle Iron on setting #3.

When preheated, green indicator light will illuminate. Pour 2 cups (500 mL) of batter along the centre of the lower grid. Allow batter to spread toward edges for 5 seconds. Close lid of waffle iron – green indicator light will turn off. When green indicator light turns on again, waffle is ready. Open lid and carefully remove baked waffle. Repeat with remaining batter. For best results, serve immediately.

*Nutritional information per waffle with yogurt:
Calories 105 (17% from fat) • carb. 17g • pro. 5g
• fat 2g • sat fat 0g • chol. 36mg • sod. 243mg
• calc. 58mg • fiber 2g*

*With 1% - fat cottage cheese:
Calories 116 (17% from fat) • carb. 17g • pro. 7g
• fat 2g • sat fat 1g • chol. 36mg • sod. 307mg
• calc. 33mg • fiber 2g*

VANILLA YOGURT PECAN WAFFLES

These waffles have a subtle, nutty sweetness and are nice and crispy.

Makes 24 waffles

- 2 cups (500 mL) unbleached flour**
- 2 cups (500 mL) whole wheat flour**
- ¼ **cup (50 mL) plus 2 tablespoons (30 mL) light brown sugar, firmly packed**
- 4 teaspoons (20 mL) baking soda**
- 1 teaspoon (5 mL) cinnamon**
- 1 teaspoon (5 mL) salt**

- 4 eggs, lightly beaten
- $\frac{2}{2}$ teaspoons (10 mL) vanilla extract
- $\frac{3}{4}$ cup (175 mL) unsalted butter, melted
- 2 cups (500 mL) vanilla yogurt, lowfat
- 2 cups (500 mL) reduced-fat milk
- 1 cup (250 mL) pecans, chopped

Place both flours, sugar, baking soda, cinnamon, and salt in a mixing bowl and stir to combine. Stir eggs and vanilla together and then stir into dry ingredients. Stir butter, yogurt, and milk into mixture successively until it resembles a smooth batter. Finally stir in chopped pecans. Let batter rest 5 minutes before using. Preheat your Cuisinart® Waffle Iron on setting #3.

When preheated, green indicator light will illuminate. Pour 2 cups (500 mL) of batter onto the centre of the lower grid. Allow batter to spread toward edges for 5 seconds. Close lid of waffle iron – green indicator light will turn off. When green indicator light turns on again, waffle is ready. Open lid and carefully remove baked waffle. Repeat with remaining batter. For best results, serve immediately.

Nutritional information per waffle:
 Calories 204 (46% from fat) • carb. 22g • pro. 6g
 • fat 11g • sat fat 5g • chol. 53mg • sod. 316mg
 • calc. 73mg • fiber 2g

WHOLE WHEAT BERRY WAFFLES

Any type of berry will work for this versatile waffle

Makes 24 waffles

- $2\frac{1}{2}$ cups (625 mL) unbleached flour
- $1\frac{1}{2}$ cups (375 mL) whole wheat flour
- $\frac{1}{4}$ cup (50 mL) granulated sugar
- 2 tablespoons (30 mL) baking powder
- 2 teaspoons (10 mL) salt
- 4 eggs, lightly beaten
- $3\frac{1}{2}$ cups (875 mL) whole milk
- $\frac{3}{4}$ cup (175 mL) unsalted butter, melted
- 2 teaspoons (10 mL) pure vanilla extract
- $1\frac{1}{2}$ cups (375 mL) blueberries, fresh or frozen
- 2 teaspoons (10 mL) orange zest
- 1 cup (250 mL) pecans, chopped

Place both flours, sugar, baking powder, and salt in a mixing bowl and stir to combine. In a separate bowl whisk together eggs, milk and vanilla and stir into dry ingredients until mixture resembles a smooth batter. Stir in melted and cooled butter. Carefully stir in blueberries, orange zest, and pecans. Let batter rest

5 minutes before using. Preheat your Cuisinart® Waffle Iron on setting #3.

When preheated, green indicator light will illuminate. Pour 2 cups (500 mL) of batter along the centre of the lower grid. Allow batter to spread toward edges for 5 seconds. Close lid of waffle iron – green indicator light will turn off. When green indicator light turns on again, waffle is ready. Open lid and carefully remove baked waffle. Repeat with remaining batter. For best results, serve immediately.

Nutritional information per waffle:
 Calories 201 (49% from fat) • carb. 21g • pro. 5g
 • fat 11g • sat fat 5g • chol. 58mg • sod. 283mg
 • calc. 55mg • fiber 2g

SAVOURY CHEDDAR CHIVE CORNMEAL WAFFLES

These crispy, savoury waffles are good to serve with soups or your favourite chili in place of corn muffins. You may also try them with scrambled eggs and bacon for brunch or supper.

Makes 30 waffles

- $3\frac{3}{4}$ cups (925 mL) all-purpose flour
- 3 cups (750 mL) cornmeal (yellow or white)
- 3 tablespoons (45 mL) granulated sugar
- 3 tablespoons (45 mL) baking powder
- $1\frac{1}{2}$ teaspoons (7 mL) baking soda
- $\frac{3}{4}$ teaspoon (4 mL) salt
- 9 ounces (255 g) shredded sharp Cheddar cheese
- $\frac{1}{4}$ cup (50 mL) plus 2 tablespoons (30 mL) chopped fresh chives
- $5\frac{1}{4}$ cups (1.3 L) reduced-fat milk
- $\frac{3}{4}$ cup (175 mL) vegetable oil
- 6 large eggs
- $\frac{1}{2}$ teaspoon (2 mL) hot sauce, such as *Tabasco®

Place flour, cornmeal, sugar, baking powder, baking soda, and salt in a large mixing bowl; stir to combine. Add shredded Cheddar and chopped chives; stir. Place the milk, oil, eggs, and hot sauce in a separate bowl; stir with a whisk to blend. Add to the dry ingredients and stir until smooth. Let batter rest 5 minutes before using. Preheat your Cuisinart® Waffle Iron on setting #3.

When preheated, green indicator light will illuminate. Pour 2 cups (500 mL) batter just along the centre of the lower grid; allow batter to spread toward edges for 5 seconds. Close lid of waffle iron – green indicator light will turn off.

When green indicator light turns on again, waffle is ready. Open lid and carefully remove baked waffle. Repeat with remaining batter. For best results, serve immediately.

Nutritional information per waffle:
 Calories 239 • carb. 25g • pro. 8g • fat 12g
 • sat fat 2g • chol. 50mg • sod. 262 mg
 • calc. 121mg • fiber 1g

*Tabasco® is a registered trademark owned by the McIlhenney Co.

PROTEIN WAFFLES

These oatmeal waffles have a delightful taste, not to mention they are high in protein and very easy to prepare.

Makes 18 waffles

- 3 cups (750 mL) old-fashioned oats
- $1\frac{1}{2}$ cup (375 mL) unbleached flour
- $\frac{1}{4}$ cup (5 mL) plus 2 tablespoons (30 mL) sugar
- 4 teaspoons (20 mL) baking powder
- 1 teaspoon (5 mL) cinnamon
- 1 teaspoon (5 mL) salt
- 4 eggs, lightly beaten
- $\frac{3}{4}$ cup (175 mL) vegetable oil
- 1 cup (250 mL) cottage cheese
- 2 cups (500 mL) reduced-fat milk

Place oats, flour, sugar, baking powder, cinnamon, and salt in a mixing bowl. Stir to combine. Stir in remaining ingredients as listed one at a time until mixture resembles a smooth batter. Let batter rest 5 minutes before using. Preheat your Cuisinart® Waffle Iron on setting #3.

Pour 2 cups (500 mL) of batter along the centre of the lower grid. Allow batter to spread toward edges for 5 seconds. Close lid of waffle iron – green indicator light will turn off. When green indicator light turns on again, waffle is ready. Open lid and carefully remove baked waffle. Repeat with remaining batter. For best results, serve immediately.

Nutritional information per waffle:
 Calories 228 • carb. 23g • pro. 7g • fat 12g
 • sat fat 2g • chol. 50mg • sod. 261mg
 • calc. 57mg • fiber 2g

WARRANTY

Limited Three-Year Warranty

This warranty is available to consumers only. You are a consumer if you own a Cuisinart® 6-Slice Traditional Waffle Iron which was purchased at retail for personal, family or household use. Except as otherwise required under applicable law, this warranty is not available to retailers or other commercial purchasers or owners.

We warrant that your Cuisinart® 6-Slice Traditional Waffle Iron will be free of defects in materials and workmanship under normal home use for 3 years from the date of original purchase.

We suggest you complete and return the enclosed product registration card promptly to facilitate verification of the date of original purchase. However, return of the product registration card does not eliminate the need for the consumer to maintain the original proof of purchase in order to obtain the warranty benefits. In the event that you do not have proof of purchase date, the purchase date for purposes of this warranty will be the date of manufacture.

If your Cuisinart® 6-Slice Traditional Waffle Iron should prove to be defective within the warranty period, we will repair or, if we think necessary, replace it. To obtain warranty service, please call our Customer Service Center toll-free at 1-800-472-7606 or write to: Cuisinart Canada, 156 Parkshore Drive, Brampton, Ontario, L6T 5M1.

To facilitate the speed and accuracy of your return, enclose \$10.00 for shipping and handling. Please be sure to include your return address, description of the product's defect, product serial number, and any other information pertinent to the return. Please pay by cheque or money order.

NOTE: For added protection and secure handling of any Cuisinart® product that is being returned, we recommend you use a traceable, insured delivery service. Cuisinart cannot be held responsible for in-transit damage or for packages that are not delivered to us. Lost and/or damaged products are not covered under warranty.

Your Cuisinart® 6-Slice Traditional Waffle Iron has been manufactured to the strictest specifications and has been designed for use only with authorized accessories and replacement parts. This warranty expressly excludes any defects or damages caused by accessories, replacement parts or repair service other than those authorized by Cuisinart.

This warranty does not cover any damage caused by accident, misuse, shipment or other than ordinary household use. This warranty excludes all incidental or consequential damages.

Cuisinart®

SAVOR THE GOOD LIFE®



Coffeemakers



Food
Processors



Toasters



Rice Cookers



Cookware



Grills

Cuisinart offers an extensive assortment of top quality products to make life in the kitchen easier than ever. Try some of our other countertop appliances and cookware, and Savor the Good Life®.

www.cuisinart.ca

©2004 Cuisinart
Cuisinart® is a registered
trademark of Cuisinart
156 Parkshore Drive, Brampton
Ontario, L6T 5M1
Printed in China

04CC18077

IB-5287-CAN