

Cuisinart®

INSTRUCTION &
RECIPE BOOKLET



4-Slice Belgian Waffle Iron

WAF-4BC

For your safety and continued enjoyment of this product, always read the instruction book carefully before using.

IMPORTANT SAFEGUARDS

When using an electrical appliance, basic safety precautions should always be followed, including the following:

1. **READ ALL INSTRUCTIONS.**
2. Do not touch hot surfaces. Use handles and knobs.
3. To protect against fire, electrical shock, and injury to persons, **DO NOT IMMERS**E CORD, PLUG, OR UNIT in water or other liquids.
4. Close supervision is necessary when any appliance is used by or near children.
5. Unplug from outlet when not in use and before cleaning. Allow to cool before putting on or taking off parts, and before cleaning appliance.
6. Do not operate any appliance with a damaged cord or plug or after the appliance malfunctions or has been damaged in any manner. Return appliance to the nearest Cuisinart Authorized Service Facility for examination, repair, or adjustment.
7. The use of accessory attachments not recommended by Cuisinart may result in fire, electrical shock, or injury to persons.
8. Do not use outdoors.
9. Do not let power cord hang over edge of table or counter, or touch hot surfaces.
10. Do not place on or near a hot gas or electric burner, or in a heated oven.
11. Unplug the unit when finished baking waffles.
12. Do not use appliance for other than intended use.
13. Always attach plug to appliance first, then plug cord into the wall outlet. To disconnect, turn control dial to OFF setting, then remove plug from the outlet.
14. Extreme caution must be used when moving an appliance containing hot oil or other hot liquids.
15. **WARNING: TO REDUCE THE RISK OF FIRE OR ELECTRIC SHOCK, REPAIR SHOULD BE DONE ONLY BY AUTHORIZED PERSONNEL. NO USER SERVICEABLE PARTS ARE INSIDE.**

SAVE THESE INSTRUCTIONS FOR HOUSEHOLD USE ONLY

SPECIAL CORD SET INSTRUCTIONS

A short power-supply cord is provided to reduce the risks resulting from becoming entangled in or tripping over a longer cord.

An extension cord may be used if care is exercised in their use. However, the marked electrical rating of the extension cord should be at least as great as the electrical rating of the appliance, and the cord should be arranged so that it will not drape over the countertop where it can be pulled on by children or tripped over unintentionally. The extension cord should be a grounding-type 3-wire cord.

NOTICE:

This appliance must be grounded. In the event of an electrical short circuit, grounding reduces the risk of electric shock by providing an escape wire for the electric current. This appliance is equipped with a cord having a grounding wire with a grounding plug. The plug must be plugged into an outlet that is properly installed and grounded. Contact a qualified electrician if the grounding instructions are not completely understood or if doubt exists as to whether the appliance is properly grounded. Do not modify the plug in any way.

WARNING- Improper use of the grounding can result in risk of electric shock.

CONTENTS

Important Safeguards	2
Introduction	3
Parts and Features	3
Before First Use	3
Operating Instructions	3
Cleaning and Care	4
Storage	4

Tips	4
Recipes	5
Warranty	11

INTRODUCTION

Get ready for more of a good thing with the Cuisinart® 4-Slice Belgian Waffle Iron. Nonstick plates, indicator lights, “ready” tone and stay-cool pick-up panels make operation easy while the six browning levels mean your waffle will always be baked to perfection. The deep pockets hold more than just butter and syrup and our new recipes

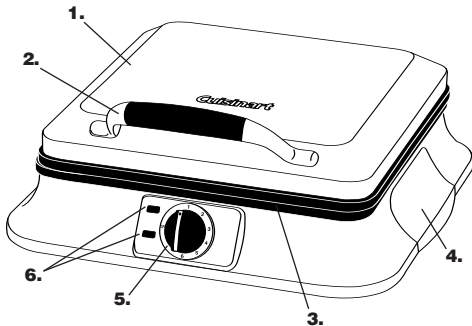

show you how to enjoy a variety of tastes, from sweet to savoury. Top chocolate waffles with ice cream for an update on the ice cream sandwich, or try cheddar cheese and chive waffles as an out-of-the-ordinary complement to soup or chili.

PARTS AND FEATURES

- Housing** – Elegant brushed stainless steel cover and base with embossed Cuisinart® logo.
- Lid Handle** – Polished chrome handle with black cool touch grip.
- Baking Plates** – Die-cast aluminum plates bake four deep-pocket Belgian waffles.
- Base Handles** – Cool-touch plastic will not become hot while baking.
- Control Dial** – Six adjustable browning settings and OFF position.
- Indicator Lights** – Red indicator light signals power on; green indicator light signals when waffle iron is ready to bake and when waffles are cooked and ready to eat.
- Audible Signal (not shown)** – Signals when waffle iron is ready to bake and waffles are cooked and ready to eat.

- Storage (not shown)** – Cord wraps under base and unit stands on back end for storing.
- Rubber Feet (not shown)** – Feet keep unit steady and won't mark countertop.

BEFORE THE FIRST USE

Remove all packaging and any promotional labels or stickers from your waffle iron. Be sure that all parts (listed above, **Parts and Features**) of your new waffle iron have been included before discarding any packaging materials. You may want to keep the box and packing materials for use at a later date.

Before using your Cuisinart® 4-Slice Belgian Waffle Iron for the first time, wipe housing and waffle plates with a damp cloth to remove any dust from the warehouse or shipping.

Note: The Cuisinart® 4-Slice Belgian Waffle Iron has been treated with a special nonstick coating. Before the first use, we suggest you season the grids with cooking spray or flavourless vegetable oil. If using oil, apply oil with a paper towel or pastry brush. You may find it helpful to repeat this process before each use of the waffle iron.

OPERATING INSTRUCTIONS

- Place the closed waffle iron on a clean, flat surface where you intend to bake.

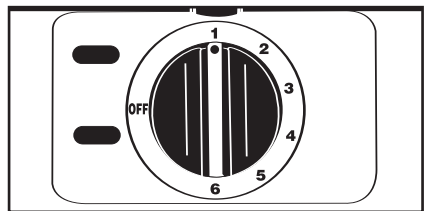

- Plug the power cord in a standard electrical outlet.
- Turn the control dial clockwise from the OFF position to the desired browning setting – setting #1 for the lightest colour waffles and setting #6 for the darkest colour waffles.

The red indicator light will turn on to signal power. Allow the waffle iron to preheat. When the waffle iron has reached desired temperature, the green indicator light will turn on and the audible tone will sound. You are now ready to begin baking.

Note: The first time you use your waffle iron it may have a slight odour and may smoke a bit. This is normal, and common to appliances with a nonstick surface.

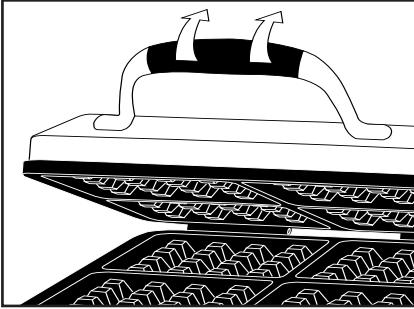

4. Lift lid of waffle iron by grasping the handle and pushing back and up in one fluid motion. Lid will stay open at 105° position until you lower it.
5. Pour batter onto the centre of the lower waffle grid. Use a heat-proof spatula to spread batter evenly over the grids. Close the lid. The green light will turn off but the red light will stay illuminated.
NOTE: Use only black touch grip when opening and closing waffle iron. Sides of the die-cast handle become warm from cooking and steam emitted from waffle iron.
6. Baking time is determined by the browning level that you chose in Step 3. It may take up to 4 minutes to bake your waffle on setting #6.
7. When the waffle is ready, the green light will turn on and the audible tone will sound. Remove the waffle by gently loosening the edges with a heat-proof plastic spatula or wooden spatula. Never use metal utensils, as they will damage the nonstick coating.
8. When you are finished baking, turn the control dial counterclockwise to the OFF setting. The red indicator light will turn off. Unplug the power cord from the wall outlet. Allow the waffle iron to cool down completely before handling.

CLEANING AND CARE

Once you have finished baking, turn the control dial to the OFF position and remove plug from electrical outlet. Leave top lid open so grids begin to cool. Allow waffle iron to cool down completely before handling.

Never take your waffle iron apart for cleaning. Simply brush crumbs from grooves, and absorb any excess cooking oil by wiping with a dry cloth or paper towel.

You may clean the grids by wiping with a damp cloth to prevent staining and sticking from batter or oil buildup. **Be certain grids have cooled completely before cleaning.** If batter adheres to plates, simply pour a little cooking oil onto the baked batter and let stand approximately 5 minutes, thus allowing it to soften for easy removal.

To clean exterior, wipe with a soft dry cloth. Never use an abrasive cleanser or harsh pad. **NEVER IMMERSE CORD, PLUG OR UNIT IN WATER OR OTHER LIQUID.**

STORAGE

Store unit in a cool, dry place with cord wrapped securely under base.

TIPS TO MAKE PERFECT WAFFLES

- Setting #1 will produce the lightest colour waffles. Setting #6 will produce the darkest colour waffles. Experiment to determine which setting produces the best waffle colour for you.
- For evenly filled waffles, pour the batter onto the centre of the lower grid and spread out evenly to the edges. The entire lower grid should be filled.
- We recommend using 1½ cups (375 ml) of batter to fill the lower grid.
- Waffles are best when made to order, but baked waffles may be kept warm in a 200°F (95°C) oven. Place them in a baking pan or wrap in foil while in the oven. (Waffles wrapped in foil may lose their crispiness.)
- Baked waffles may be frozen. Allow to cool completely, then place in plastic food storage bag. Use waxed paper to keep waffles separated. Reheat in a toaster or toaster oven when ready to eat.

- For added flavour, dress your waffles with fruit syrups, warm fruit compote, fresh berries, chopped fruit or yogurt.
- For sweeter waffles add powdered sugar, whipped cream, ice cream or chocolate sauce.

Makes 24 waffles

RECIPES

Basic Waffles

Fresh, homemade waffles make breakfast a special occasion. Freeze the extras to use when time is scarce.

Makes 20 waffles

- 4 cups (1 L) all-purpose flour**
- 4 tablespoons (60 ml) granulated sugar**
- 2 tablespoons (30 ml) baking powder**
- 1 teaspoon (5 ml) baking soda**
- 1 teaspoon (5 ml) salt**
- 3½ cups (875 ml) lowfat milk**
- ¾ cup (175 ml) vegetable oil**
- 4 large eggs**

Place ingredients in a large mixing bowl and combine until well blended and smooth. Let batter rest 5 minutes before using. Preheat your Cuisinart® Waffle Iron.

When the iron is ready, the audible signal will sound and green indicator light will illuminate. Pour 1½ cups (375 ml) batter onto the centre of the lower grid; spread batter using a heatproof spatula to within ½ inch (1.25 cm) of the edge of the grid. Close lid of waffle iron – green indicator light will turn off. When audible signal sounds and green indicator light turns on again, waffle is ready. Open lid and carefully remove baked waffle. Repeat with remaining batter.

Nutritional information per waffle:
Calories 174 (44% from fat) • carb. 24g • pro. 5g
• fat 10g • sat. fat 1g • chol. 46mg • sod. 298mg
• calc. 142mg • fiber 1g

Light and Crispy Buttermilk Waffles

Whipping the egg whites makes these waffles extra-light and crispy.

- 3 cups (750 ml) unbleached, all-purpose flour**
- ¼ cup (50 ml) plus 2 tablespoons (30 ml) granulated sugar**
- 1 tablespoon (15 ml) baking powder**
- 1½ teaspoons (7 ml) baking soda**
- ¾ teaspoon (4 ml) salt**
- 1¾ cups (425 ml) buttermilk**
- 9 tablespoons (135 ml) unsalted butter, melted**
- 1½ teaspoons (7 ml) pure vanilla extract**
- 4 large eggs, separated**
- 1 large egg white**

Place flour, sugar, baking powder, baking soda, and salt in a mixing bowl and stir to combine. In a separate bowl, whisk together buttermilk, melted butter, vanilla, and egg yolks and stir into dry ingredients until mixture resembles a smooth batter. Add extra white to bowl of whites and whip to firm, but not dry, peaks using an electric mixer. Preheat your Cuisinart® Waffle Maker.

Carefully fold whites into batter in three additions using a large rubber spatula, until the whites and batter are completely incorporated.

When the iron is ready, the audible signal will sound and green indicator light will illuminate. Pour 1½ cups (375 ml) batter onto the centre of the lower grid; spread batter using a heatproof spatula to within ½ inch (1.25 cm) of the edge of the grid. Close lid of waffle iron – green indicator light will turn off. When audible signal sounds and green indicator light turns on again, waffle is ready. Open lid and carefully remove baked waffle. Repeat with remaining batter.

Nutritional information per waffle:
Calories 127 (39% from fat) • carb. 16g • pro. 3g
• fat 5g • sat. fat 3g • chol. 48mg • sod. 222mg
• calc. 37mg • fiber 0g

Sweet Belgian Yeast Waffles

These waffles bake with crispy exteriors and light, fluffy interiors.

Makes 20 waffles

Waffles

- 1 package active dry yeast [2¼ teaspoons (11 ml)]**
- ¼ cup (50 ml) warm water [105°F-110°F (40°C-43°C)]**
- ¾ cup (175 ml) unsalted butter**
- 2¾ cups (675 ml) warm lowfat milk**
- 3 cups (750 ml) unbleached, all-purpose flour**
- 1 cup (250 ml) cornstarch**
- 3 eggs, separated**
- ½ cup (125 ml) granulated sugar, divided**
- 1 teaspoon (5 ml) salt**
- 2 teaspoons (10 ml) pure vanilla extract**

Stir yeast and sugar into warm water in a small bowl; let stand until foamy, about 3 to 5 minutes. Warm butter and milk together in a small saucepan over low heat so that the butter melts but the milk does not exceed 110°F (43°C) [if mixture is hotter than 110°F (43°C), allow to cool to 105–110°F (40°C-43°C) before continuing]. Reserve. Combine the flour and cornstarch in a separate bowl; reserve.

In a large bowl, whisk together the egg yolks, milk and butter mixture, yeast mixture, ¼ cup (50 ml) of the sugar, salt, and vanilla. Stir in the milk and flour/cornstarch mixture alternately, ending with the flour. Wrap in plastic and let stand until mixture is doubled in volume, about an hour. Preheat your Cuisinart® Waffle Iron.

Whip egg whites until frothy, and then add remaining ¼ cup (50 ml) sugar. Continue to whip until firm peaks form. Carefully fold whites into waffle batter using a large rubber spatula.

When iron is ready, the audible signal will sound and green indicator light will illuminate. Pour 1½ cups (375 ml) batter onto the centre of the lower grid; spread batter using a heatproof spatula to within ½ inch (1.25 cm) of the edge of the grid. Close lid of waffle iron – green indicator light will turn off. When audible signal sounds and green indicator light turns on again, waffle is ready. Open lid and carefully remove baked waffle. Repeat with remaining batter.

Nutritional information per waffle:
Calories 203 (38% from fat) • carb. 27g • pro. 4g
• fat 9g • sat. fat 5g • chol. 53mg • sod. 149mg
• calc. 57mg • fiber 1g

A great brunch or dessert waffle.

Makes 16 waffles

- 2 cups (500 ml) all-purpose flour**
- ¾ cup (175 ml) granulated sugar**
- ¾ cup (150 ml) unsweetened cocoa powder**
- 3 teaspoons (45 ml) baking powder**
- ½ teaspoon (2 ml) baking soda**
- ½ teaspoon (2 ml) salt**
- ½ teaspoon (2 ml) cinnamon**
- 2 cups (500 ml) lowfat milk**
- 2 large eggs, lightly beaten**
- 2 teaspoons (10 ml) pure vanilla extract**
- ½ cup (125 ml) unsalted butter, melted, cooled slightly**
- 1 cup (250 ml) semi-sweet mini chocolate morsels**
- ½ cup (125 ml) finely chopped walnuts or pecans**

Place the flour, sugar, cocoa powder, baking powder, baking soda, salt, and cinnamon in a medium bowl; stir with a whisk to blend. Add the milk, egg and vanilla. Stir with a whisk until well blended and smooth. Stir in melted butter. Let batter stand 5 minutes. Preheat your Cuisinart® Waffle Iron.

When iron is ready, the audible signal will sound and green indicator light will illuminate. Stir chocolate morsels and chopped walnuts/pecans into batter. Pour 1½ cups (375 ml) batter onto centre of the lower grid; spread the batter using a heatproof spatula to within ½ inch (1.25 cm) of the edge of the grid. Close lid of waffle iron – green indicator light will turn off. When audible signal sounds and green indicator light turns on again, waffle is ready. Remove waffle using a heatproof plastic spatula. Repeat with remaining batter.

Nutritional analysis per waffle:
Calories 237 (45% from fat) • carb. 30g • pro. 5g

• fat 12g • sat. fat 6g • chol. 44mg • sod. 176mg
• calc. 55mg • fiber 2g

Chocolate Brownie

Apple Walnut Waffles

Stir a teaspoon of cinnamon into maple syrup and warm to serve with Apple Walnut Waffles.

Makes 20 waffles

- 6** **tablespoons (90 ml) packed brown sugar**
- 2½** **cups (650 ml) unbleached all-purpose flour**
- ½** **cup (125 ml) whole wheat flour**
- ½** **cup (125 ml) honey toasted wheat germ**
- 2** **tablespoons (30 ml) baking powder**
- 1** **teaspoon (5 ml) salt**
- 3** **cups (750 ml) lowfat milk**
- 4** **large eggs, lightly beaten**
- ¾** **cup (150 ml) vegetable oil**
- 1** **teaspoon (5 ml) vanilla extract**
- 2** **cups (500 ml) finely diced or shredded apple (1 apple, 8 ounces, peeled & cored)**
- 1** **cup (250 ml) finely chopped walnuts**

Crumble the brown sugar into a medium bowl to remove all lumps. Add both flours, wheat germ, baking powder and salt. Stir to blend. In another bowl, combine the milk, eggs, oil, and vanilla; stir with a whisk. Add the wet mixture to the dry mixture and stir until smooth. Stir in the apple and walnuts. Let batter rest 5 minutes before using. Preheat your Cuisinart® Waffle Iron.

When iron is ready, audible signal will sound and green indicator light will illuminate. Pour 1½ cups (375 ml) batter onto the centre of the lower grid; spread batter using a heatproof spatula to within ½ inch (1.25 cm) of the edge of the grid. Close lid of waffle iron – green indicator light will turn off. When audible signal sounds and green indicator light turns on again, waffle is ready. Open lid and carefully remove baked waffle. Repeat with remaining batter.

Nutritional information per waffle:
Calories 244 (47% from fat) • carb. 26g • pro. 6g
• fat 13g • sat. fat 2g • chol. 45mg • sod. 255mg
• calc. 68mg • fiber 1g

Cinnamon Waffles

Top these tasty waffles with warm maple syrup and fresh fruit.

Makes 20 waffles

- ¼** **cup (50 ml) packed light brown sugar**
- 4** **cups (1 L) all-purpose flour**
- 2** **tablespoons (30 ml) baking powder**
- 1** **teaspoon (5 ml) baking soda**
- 3** **teaspoons (15 ml) ground cinnamon**
- 1** **teaspoon (5 ml) salt**
- 3½** **cups (875 ml) lowfat milk**
- ¾** **cup (175 ml) vegetable oil**
- 4** **large eggs, lightly beaten**

Crumble the brown sugar to remove all lumps and place in a medium mixing bowl with the flour, baking powder, cinnamon, baking soda, and salt. Add the milk, oil and eggs; stir until blended and smooth. Let batter rest 5 minutes before using. Preheat your Cuisinart® Waffle Iron.

When iron is ready, the audible signal will sound and green indicator light will illuminate. Pour 1½ cups (375 ml) batter onto the centre of the lower grid; spread batter using a heatproof spatula to within ½ inch (1.25 cm) of the edge of the grid. Close lid of waffle iron – green indicator light will turn off. When audible signal sounds and green indicator light turns on again, waffle is ready. Open lid and carefully remove baked waffle. Repeat with remaining batter.

Nutritional information per waffle:
Calories 236 (55% from fat) • carb. 22g • pro. 5g
• fat 15g • sat. fat 2g • chol. 38mg • sod. 230mg
• calc. 59 mg • fiber 2g

Banana Almond Waffles

Classic waffle for a weekend brunch – top with warm syrup.

Makes 20 waffles

- 4** **cups (1 L) unbleached all-purpose flour**
- ¼** **cup (50 ml) granulated sugar**
- 4** **teaspoons (20 ml) baking powder**
- 2** **teaspoons (10 ml) baking soda**
- 1** **teaspoon (5 ml) salt**
- 4** **eggs, lightly beaten**
- ¾** **cup (175 ml) vegetable oil**
- 2** **cups (500 ml) lowfat plain yogurt**
- 1½** **cups (375 ml) whole milk**
- 2** **cups (500 ml) mashed banana**
- 1** **cup (250 ml) chopped almonds**

Combine flour, sugar, baking powder, baking soda, and salt in a mixing bowl and stir to combine. In a separate bowl whisk together the eggs and oil and stir into dry ingredients. Stir in yogurt. Add milk and stir until mixture is a smooth batter. Stir in banana and almonds until incorporated. Let batter rest 5 minutes before using. Preheat your Cuisinart® Waffle Iron.

When iron is ready, the audible signal will sound and green indicator light will illuminate. Pour 1½ cups (375 ml) of batter onto the centre of the lower grid; spread batter using a heatproof spatula to within ½ inch (1.25 cm) of the edge of the grid. Close lid of waffle iron – green indicator light will turn off. When audible signal sounds and green indicator light turns on again, waffle is ready. Open lid and carefully remove baked waffle. Repeat with remaining batter.

Nutritional information per waffle:
Calories 248 (48% from fat) • carb. 27g • pro. 6g
• fat 13g • sat. fat 2g • chol. 38mg • sod. 312mg
• calc. 66mg • fiber 1g

Oatmeal Raisin Waffles

These waffles taste like an oatmeal raisin cookie. They are delicious when spread with apple butter.

Makes 20 waffles

- 6 tablespoons (90 ml) packed light brown sugar
- 3 cups (750 ml) all-purpose flour
- 2 cups (500 ml) oatmeal (regular rolled oats, not quick oats)
- 4 teaspoons (20 ml) ground cinnamon
- 3 teaspoons (15 ml) baking powder
- 2 teaspoons (10 ml) baking soda
- 1 teaspoon (5 ml) salt
- 3 cups (750 ml) buttermilk
- 4 large eggs, lightly beaten
- ¾ cup (175 ml) vegetable oil (you may substitute unsalted butter, melted and cooled)
- 1 teaspoon (5 ml) vanilla extract
- 1½ cups (325 ml) raisins

Crumble the brown sugar to remove any lumps and place in a medium bowl with flour, oatmeal, cinnamon, baking powder, baking soda, and salt. Stir to blend. Add buttermilk, eggs, oil, and vanilla. Stir until well blended and smooth. Stir

in raisins. Let batter rest 5 minutes before using. Preheat your Cuisinart® Waffle Iron.

When iron is ready, the audible signal will sound and green indicator light will illuminate. Pour a scant 1½ cup (375 ml) of batter onto the centre of the lower grid; spread batter using a heatproof spatula to within ½ inch (1.25 cm) of the edge of the grid. Close lid of waffle iron – green indicator light will turn off. When audible signal sounds and green indicator light turns on again, waffle is ready. Open lid and remove baked waffle. Repeat with remaining batter.

Nutritional information per waffle:
Calories 250 (36% from fat) • carb. 35g • pro. 6g
• fat 10g • sat. fat 1g • chol. 44mg • sod. 316mg
• calc. 69mg • fiber 2g

Lemon Waffles

These waffles are a fresh change – if you want, add blueberries for Lemon Blueberry Waffles.

Makes 24 waffles

- 1½ cups (375 ml) unbleached flour
- 1½ cups (375 ml) cornstarch
- ½ cup (125 ml) granulated sugar
- 1 tablespoon (15 ml) baking powder
- 1 teaspoon (5 ml) baking soda
- 1 teaspoon (5 ml) salt
- 4 eggs
- 1½ cups (325 ml) lowfat milk
- 2 teaspoons (10 ml) pure vanilla extract
- ¾ cup (175 ml) unsalted butter, melted
- 1 cup (250 ml) plain lowfat yogurt
- ½ cup (125 ml) fresh lemon juice
- ¼ cup (50 ml) lemon zest

Place flour, cornstarch, sugar, baking powder, baking soda, and salt in mixing bowl and stir to combine. In a second bowl, whisk eggs, milk, and vanilla until blended. Stir wet mixture into dry ingredients. Fold in melted butter and then yogurt with a rubber spatula or wooden spoon. Stir in lemon juice and zest. Preheat your Cuisinart® Waffle Iron.

When iron is ready, the audible signal will sound and the green indicator light will illuminate. Pour 1½ cups (375 ml) of batter onto the centre of the lower grid; spread batter using a heatproof spatula to within ½ inch (1.25 cm) of the edge of the grid. Close lid of waffle iron – green indicator

light will turn off. When green indicator light turns on again, waffle is ready. Open lid and carefully remove baked waffle. Repeat with remaining batter.

Variations: For lemon ginger waffles add 1 tablespoon (15 ml) of grated fresh ginger to the batter with the juice and zest. For lemon blueberry waffles add 1 cup (250 ml) of blueberries to the batter as the last ingredient.

Nutritional information per waffle:
Calories 156 (41% from fat) • carb. 20g • pro. 3g
• fat 7g • sat. fat 4g • chol. 52mg • sod. 197mg
• calc. 53mg • fiber 0g

Super Multigrain Blueberry Waffles

High in protein, these crispy waffles have a nice texture and pleasant flavour – you would never know they are also good for you.

Makes 24 waffles

- 2 cups (500 ml) whole wheat flour
- 1 cup (250 ml) unbleached flour
- 1 cup (250 ml) old-fashioned oats
- 2 teaspoons (10 ml) baking powder
- 2 teaspoons (10 ml) baking soda
- 1 teaspoon (5 ml) salt
- 4 eggs, lightly beaten
- 2 cups (500 ml) soymilk
- ¼ cup (50 ml) 100% pure maple syrup (not pancake syrup)
- 2 teaspoons (10 ml) vanilla extract
- ¾ cup (175 ml) unsalted butter, melted
- ¼ cup (50 ml) flaxseed oil
- 2 cups (500 ml) lowfat yogurt
- 1 cup (250 ml) blueberries, fresh or frozen
- 1 cup (250 ml) pecans or walnuts, finely chopped

Place whole wheat flour, unbleached flour, oats, baking soda, baking powder, and salt in mixing bowl and stir to combine. In a separate bowl stir together eggs, soymilk, syrup, and vanilla and add to the dry ingredients. Stir in butter, flaxseed oil, and yogurt. Finally stir blueberries and chopped nuts into batter. Let batter rest 5 minutes before using. Preheat your Cuisinart® Waffle Iron.

When iron is ready, the audible signal will sound and green indicator light will illuminate. Pour 1½ cups (375 ml) of batter onto the centre of the lower grid; spread batter using a heatproof spatula to within ½ inch (1.25 cm) of the edge of the grid. Close lid of waffle iron – green indicator light will turn off. When green indicator light turns on again, waffle is ready. Open lid and carefully remove baked waffle. Repeat with remaining batter.

Nutritional information per waffle:
Calories 137 (33% from fat) • carb. 18g • pro. 6g
• fat 5g • sat. fat 1g • chol. 48mg • sod. 243mg
• calc. 62mg • fiber 2g

Whole Wheat Berry Waffles

Any type of berry will work for this versatile waffle.

Makes 20 waffles

- 2½ cups (625 ml) unbleached all-purpose flour
- 1½ cups (375 ml) whole wheat flour
- 4 tablespoons (60 ml) granulated sugar
- 2 tablespoons (30 ml) baking powder
- 2 teaspoons (10 ml) salt
- 4 eggs, lightly beaten
- 3½ cups (875 ml) lowfat milk
- ¾ cup (175 ml) unsalted butter, melted
- 2 teaspoons (10 ml) pure vanilla extract
- 1½ cups (375 ml) blueberries or any variety of berry, fresh or frozen
- 2 teaspoons (10 ml) orange zest
- 1 cup (250 ml) pecans, chopped

Place both flours, sugar, baking powder, and salt in a mixing bowl and stir to combine. In a separate bowl whisk together eggs, milk, melted butter and vanilla and stir into dry ingredients until mixture resembles a smooth batter. Carefully stir in blueberries, orange zest, and pecans. Let batter rest 5 minutes before using. Preheat your Cuisinart® Waffle Iron.

When iron is ready, the audible signal will sound and green indicator light will illuminate. Pour 1½ cups (375 ml) of batter onto the centre of the lower grid; spread batter using a heatproof spatula to within ½ inch (1.25 cm) of the edge of the grid. Close lid of waffle iron – green indicator

light will turn off. When audible signal sounds and green indicator light turns on again, waffle is ready. Open lid and carefully remove baked waffle. Repeat with remaining batter.

Nutritional information per waffle:
Calories 254 (47% from fat) • carb. 28g • pro. 6g
• fat 13g • sat. fat 6g • chol. 67mg • sod. 340mg
• calc. 66mg • fiber 2g

Sweet Biscuit Waffles

A variation of a centuries-old classic waffle from Belgium.

Makes 20 waffles

- 4–5 ounces (113 g–141 g) sweet biscuits, such as arrowroot cookies**
- 3 cups (750 ml) lowfat milk**
- ½ cup (125 ml) unsalted butter**
- 4 cups (1 L) unbleached, all-purpose flour**
- 1 tablespoon (15 ml) baking powder**
- 1 teaspoon (5 ml) baking soda**
- ¼ cup (50 ml) granulated sugar**
- ½ teaspoon (2 ml) salt**
- 3 large eggs, separated**

Place biscuits in a large mixing bowl. Place milk and butter in a small saucepan over medium low and heat until butter is melted. Pour warm milk and butter over biscuits and stir until they are dissolved, about 1 minute. To the milk mixture, whisk in flour, baking powder, baking soda, sugar, salt, and egg yolks until mixture resembles a smooth batter. Preheat your Cuisinart® Waffle Iron.

Whip egg whites to firm, but not dry, peaks using an electric mixer. Carefully fold whites into batter in two additions, using a large rubber spatula, until the whites and batter are completely incorporated.

When iron is ready, the audible signal will sound and green indicator light will illuminate. Pour 1½ cups (375 ml) batter onto the centre of the lower grid; spread batter using a heatproof spatula to within ½ inch (1.25 cm) of the edge of the grid. Close lid of waffle iron – green indicator light will turn off. When audible signal sounds and green indicator light turns on again, waffle is ready. Open lid and carefully remove baked waffle. Repeat with remaining batter.

Nutritional information per waffle:

Calories 194 (30% from fat) • carb. 28g • pro. 5g
• fat 2g • sat. fat 4g • chol. 47mg • sod. 224mg
• calc. 810mg • fiber 1g

Chocolate Chip Graham Cracker Waffles

A sweet treat for breakfast, or top with vanilla ice cream for a comfort food dessert.

Makes 24 waffles

- ¼ cup (50 ml) packed brown sugar**
- 2½ cups (650 ml) all-purpose flour**
- 1½ cups (325 ml) graham cracker crumbs**
- ¼ cup (50 ml) granulated sugar**
- 2 tablespoons (30 ml) baking powder**
- ½ teaspoon (2 ml) baking soda**
- 1 teaspoon (5 ml) cinnamon**
- 1 teaspoon (5 ml) salt**
- 3½ cups (875 ml) lowfat milk**
- 4 large eggs, separated**
- ¼ cup (175 ml) unsalted butter, melted and cooled slightly**
- 1 teaspoon (5 ml) pure vanilla extract**
- 1½ cups (325 ml) mini chocolate morsels**
- ¾ cup (150 ml) finely chopped nuts (walnuts, pecans, almonds or hazelnuts)**

Crumble brown sugar into a large mixing bowl. Add flour, graham cracker crumbs, sugar, baking powder, baking soda, cinnamon and salt. Stir and reserve. Combine milk and egg yolks, stir until smooth. Stir in melted butter and vanilla; reserve. Whip egg whites until stiff peaks form. Add milk mixture to dry mixture and stir until smooth. Fold in chocolate morsels and nuts. Stir ½ of the whipped egg whites gently into the batter to lighten. Fold in remaining egg whites gently, taking care not to deflate. Let batter rest 5 minutes before using. Preheat your Cuisinart® Waffle Iron.

When iron is ready, the audible signal will sound and green indicator light will illuminate. Pour 1½ cups (375 ml) batter onto the centre of the lower grid; spread batter using a heatproof spatula to within ½ inch (1.25 cm) of the edge of the grid. When audible signal sounds and green indicator light turns on again, waffle is ready. Repeat with remaining batter.

Nutritional information per waffle:
Calories 269 (48% from fat) • carb. 30g • pro. 5g

• fat 14g • sat. fat 3g • chol. 46mg • sod. 281mg
• calc. 63mg • fiber 2g

262mg
• calc. 121mg • fiber 1g

*Tabasco is a registered trademark owned by
McIlhenny Co.

Savoury Cheddar Chive Cornmeal Waffles

These crispy, savoury waffles are good to serve with soups or your favourite chili in place of corn muffins. You may also try them with scrambled eggs and bacon for brunch or supper.

Makes 20 waffles

- 2½ cups (625 ml) all-purpose flour**
- 2 cups (500 ml) cornmeal (yellow or white)**
- 2 tablespoons (30 ml) granulated sugar**
- 2 tablespoons (30 ml) baking powder**
- 1 teaspoon (5 ml) baking soda**
- ½ teaspoon (2 ml) salt**
- 6 ounces (170 g) shredded sharp Cheddar cheese [about 1½ cup (375 ml)]**
- 4 tablespoons (60 ml) chopped fresh chives**
- 3½ cups (875 ml) lowfat milk**
- ¾ cup (175 ml) vegetable oil**
- 4 large eggs**
- 6–10 dashes hot sauce, such as *Tabasco®**

Place flour, cornmeal, sugar, baking powder, baking soda, and salt in a large mixing bowl; stir to combine. Add shredded Cheddar and chopped chives; stir. Place the milk, oil, eggs, and hot sauce a separate bowl; stir with a whisk to blend. Add to the dry ingredients and stir until smooth. Let batter rest 5 minutes before using. Preheat your Cuisinart® Waffle Iron.

When iron is ready, the audible signal will sound and green indicator light will illuminate. Pour 1½ cups (375 ml) batter onto the centre of the lower grid; spread batter using a heatproof spatula to within ½ inch (1.25 cm) of the edge of the grid. Close lid of waffle iron – green indicator light will turn off. When audible signal sounds and green indicator light turns on again, waffle is ready. Open lid and carefully remove baked waffle. Repeat with remaining batter.

Nutritional information per waffle:
Calories 239 (45% from fat) • carb. 25g • pro.
8g
• fat 12g • sat. fat 2g • chol. 50mg • sod.

WARRANTY LIMITED THREE-YEAR WARRANTY

This warranty supersedes all previous warranties on this Cuisinart® product. This warranty is available to consumers only. You are a consumer if you own a Cuisinart® product that was purchased at retail for personal, family or household use. This warranty is not available to retailers or other commercial purchasers or owners.

We warrant that this Cuisinart® product will be free of defects in material or workmanship under normal home use for three years from the date of original purchase.

For warranty purposes, we would like to suggest that you register your product on-line at www.cuisinart.ca to facilitate verification of the date of original purchase. However, should you not wish to register on-line we recommend the consumer to maintain original receipt indicating proof of purchase. In the event that you do not have proof of purchase date, the purchase date for purposes of this warranty will be the date of manufacture.

When calling our Authorized Service Centre for in warranty service please make reference to your model number and the manufacturing date code. This information can be found in the rating area on the body or underneath the base of your unit. The model number will follow the word Model: WAF-4BC. The manufacturing date code is a 4 or 5 digit number. Example, 70630 would designate year, month & day (2007, June 30th).

If your Cuisinart® product should prove to be defective within the warranty period, we will repair it or, if we think it necessary, replace it. To obtain warranty service, please call our Consumer Service Centre toll-free at 1-800-472-7606 or write to:

Cuisinart Canada
100 Conair Parkway,
Woodbridge, Ontario L4H 0L2

To facilitate the speed and accuracy of your return, please also enclose \$10.00 for shipping and handling of the product. Please also be sure to include a return address, description of the product defect, product serial number, and any other information pertinent to the product's return. Please pay by cheque or money order.

NOTE: For added protection and secure handling of any Cuisinart® product that is being returned, we recommend you use a traceable, insured delivery service.

Cuisinart cannot be held responsible for in transit damage or for packages that are not delivered to us. Lost and/or damaged products are not covered under warranty.

Your Cuisinart® product has been manufactured to strict specifications and has been designed for use with Cuisinart® authorized accessories and replacement parts for your model.

These warranties expressly exclude any defects or damages caused by accessories, replacement parts or repair service other than those that have been authorized by Cuisinart. These warranties exclude all incidental or consequential damages.

BEFORE RETURNING YOUR CUISINART PRODUCT

Important: If the nonconforming product is to be serviced by someone other than Cuisinart's Authorized Service Centre, please remind the servicer to call our Consumer Service Centre to ensure that the problem is properly diagnosed, the product serviced with the correct parts, and to ensure that the product is still under warranty.

Cuisinart®

SAVOR THE GOOD LIFE®



Coffeemakers



Food
Processor



Toasters



Rice Cookers



Cookware



Grills

Cuisinart offers an extensive assortment of top quality products to make life in the kitchen easier than ever. Try some of our other countertop appliances and cookware, and Savor the Good Life®.

www.cuisinart.ca

©2007 Cuisinart
Cuisinart® is a registered
trademark of Cuisinart

Cuisinart Canada
100 Conair Parkway,
Woodbridge, Ontario
L4H 0L2

Printed in China
04CC18153

E IB-5711-CAN-B-TK