

Cuisinart™

INSTRUCTION AND RECIPE BOOKLET



Professional Belgian Waffle Maker

WAF-300C

For your safety and continued enjoyment of this product, always read the instruction book carefully before using.

IMPORTANT SAFEGUARDS

When using electrical appliances, basic safety precautions should always be followed including the following:

1. **READ ALL INSTRUCTIONS.**
2. Do not touch hot surfaces. Use handles and knobs.
3. To protect against fire, electrical shock, and injury to persons, **DO NOT IMMERS**E CORD, PLUG, OR UNIT in water or other liquids.
4. Close supervision is necessary when any appliance is used by or near children.
5. Unplug from outlet when not in use and before cleaning. Allow to cool before putting on or taking off parts, and before cleaning appliance.
6. Do not operate any appliance with a damaged cord or plug, or after the appliance malfunctions or has been damaged in any manner.
7. The use of accessory attachments not recommended by Cuisinart™ may result in fire, electrical shock, or injury to persons.
8. Do not use outdoors, or use for other than intended use.
9. Do not let power cord hang over edge of table or counter, or touch hot surfaces.
10. Do not place on or near a hot gas or electric burner, or in a heated oven.
11. Unplug the unit when finished baking waffles.
12. Always begin by plugging appliance into wall outlet. To disconnect, turn control to setting #1, then remove plug from wall outlet.
13. Extreme caution must be used when moving an appliance containing hot oil or other hot liquids.
14. **WARNING:** TO REDUCE THE RISK OF FIRE OR ELECTRIC SHOCK, REPAIR SHOULD BE DONE ONLY BY AUTHORIZED PERSONNEL. **DO NOT REMOVE THE BASE PANEL. NO USER SERVICEABLE PARTS ARE INSIDE.**

SAVE THESE INSTRUCTIONS FOR HOUSEHOLD USE ONLY

SPECIAL CORD SET INSTRUCTIONS

A short power-supply cord is provided to reduce the risks resulting from becoming entangled in or tripping over a longer cord. Longer extension cords are available and may be used if care is exercised in their use.

If a long extension cord is used, the marked electrical rating of the extension cord should be at least as great as the electrical rating of the appliance, and the longer cord should be arranged so that it will not drape over the countertop or tabletop where it can be pulled on by children or animals, or tripped over.

NOTICE

For your protection, the Cuisinart™ Professional Waffle Maker is supplied with a molded 3-prong grounding-type plug and should be used in combination with a properly connected grounding-type outlet.

TABLE OF CONTENTS

Important Safeguards.....	2
Introduction	3
Parts and Features	3
Before First Use	3
Operating Instructions.....	4
Cleaning and Care.....	4
Tips.....	5
Suggested Toppings	5
Recipes.....	6
Warranty	11

INTRODUCTION

Cuisinart™ has always had a flair for the dramatic, and your new Professional Belgian Waffle Maker is one of the best examples yet! The look is solid – a cross between commercial and consumer, with brushed stainless steel that’s upscale and elegant. With extra deep pockets and an easy-to-handle rotary feature for even baking and browning, you’ll love the options that this waffle maker provides.

Plates are non-stick, so heat them up and get cooking! Enjoy great breakfasts and creative desserts. Happy waffling!

PARTS AND FEATURES

- 1. Deep ½" (1.25 cm) Waffle Grids**
- 2. Browning Control Adjustment** - Adjustable for different batters and personal preference.
- 3. Indicator Lights** -
 - Red signal indicates waffle maker is in “On” position.
 - Green signal indicates waffle maker is “Ready to Bake”.
- 4. Indicator Beeps** - 6 beeps indicate unit is ready to bake. When the waffle maker is first plugged into electrical outlet and turned to the “On” position, the waffle maker will beep 6 times, indicating it has reached baking temperature (not shown).

Please note: this will only occur for the first waffle of each baking session.

- 3 beeps indicate waffle is done.

- 5. Lockdown Lid** - Lid will not rise as waffles bake.
- 6. Folding Handle** - For easy storage.
- 7. Measuring Scoop**

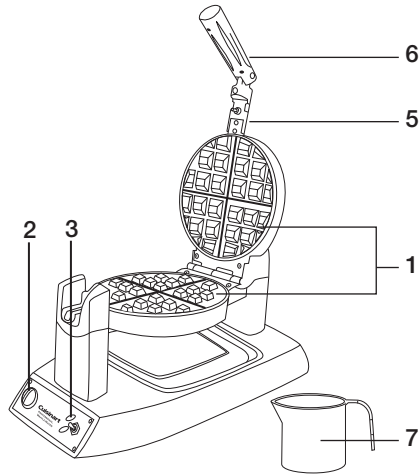

BEFORE FIRST USE

Remove all packaging and any promotional labels or stickers from your waffle maker. Be sure that all parts (listed above, **Parts and Features**) of your new waffle maker have been included before discarding any packaging materials. You may want to keep the box and packing materials for use at a later date.

Before using your Cuisinart™ Professional Belgian Waffle Maker for the first time, wipe housing and waffle plates with a damp cloth to remove any dust from the warehouse or shipping.

Note: The Cuisinart™ Professional Belgian Waffle Maker has been treated with a special nonstick coating. Before the first use, we suggest you season the grids with cooking spray or flavourless vegetable oil. If using oil, apply oil with a paper towel or pastry brush. You may find it helpful to repeat this process before each use of the waffle maker.

OPERATING INSTRUCTIONS

1. Plug cord into 120V AC wall or outlet. Switch the toggle switch to the "On" position. The red light will go on to signal power. The waffle maker will now begin the preheating process. This should take about 4 minutes. The waffle maker will sound 6 beeps and the green indicator light will go on to signal the unit is ready for baking. Season the waffle grids by spraying with cooking spray or brushing with a flavourless oil. For initial use, it is important that the waffle maker is preheated before seasoning with cooking spray or oil.

Note: The first time you use your waffle maker, it may have a slight odour and may smoke a bit. This is normal, and common to heating appliances.

2. Push slide button on handle into up position to extend the handle for baking waffles. When baking is completed, push button on handle into down position to collapse for compact storage.
3. Preheat your Cuisinart™ Belgian Waffle Maker on setting #4 or preferred setting (green indicator light will be illuminated when preheated). For best results, do not open waffle maker during cooking process. Doing so will offset the timing mechanism.
4. Using the recipes provided (fill measuring scoop to fill line $\frac{3}{4}$ or to top of measuring scoop depending on the recipe. For loose batters, fill to the $\frac{3}{4}$ mark; for thicker batters fill to the top) and pour batter evenly into the centre of the waffle grids. Use a heatproof spatula to spread the batter evenly over the grids. Close the lid and rotate the unit 180° to the right.

5. When the waffle is completely baked, the waffle maker will sound 3 beeps. Baking time is determined by browning level. Choose a setting on the browning control dial. For golden brown waffles, we recommend using setting #4.
6. Once the waffle is ready and the waffle maker has beeped 3 times, rotate the waffle maker 180° to the left, open the lid and remove waffle by gently loosening the edges with a heatproof plastic spatula. Never use metal utensils, as they may damage the nonstick coating.
7. Always disconnect the plug from the wall outlet, once baking has been completed.

CLEANING AND CARE

Once you have finished baking, switch toggle to the "Off" position; remove plug from electrical outlet. Leave top lid open and allow grids to cool before cleaning.

Never take your Belgian waffle maker apart for cleaning. Simply brush crumbs from grooves, and absorb any excess cooking oil by wiping with a dry cloth or paper towel. You may clean the grids by wiping with a damp cloth, to prevent staining and sticking from batter or oil buildup. Be certain that grids have cooled completely before cleaning. If batter adheres to plates, simply pour a little cooking oil onto the baked batter and let stand approximately 5 minutes, allowing batter to soften for easy removal.

To clean exterior, wipe with a soft dry cloth. Never use an abrasive cleanser or harsh pad. **NEVER IMMERSE CORD, PLUG OR UNIT IN WATER OR OTHER LIQUID.**

TIPS FOR MAKING PERFECT BELGIAN WAFFLES

- We recommend setting #4 when using commercial pancake/waffle mixes.
- We recommend setting #4 for Belgian waffle recipes. If you prefer crisper, darker Belgian waffles, increase the browning control.
- For evenly filled waffles, pour the batter into the centre of the lower grid and spread out evenly to the edges. The entire lower grid should be filled.
- For best results, we recommend using $\frac{3}{4}$ cup batter or enough to fill the entire lower grid.
- For added convenience while baking waffles, rest measuring scoop with handle hanging on outside of bowl, and scoop on inside of bowl, until the next baking cycle.
- To measure flour, stir the flour first to aerate it, since it settles when it sits. Then spoon it into a measuring cup, leveling off the top with the back of a knife – do not pack down into measuring cup. These quick steps will help you avoid heavy waffles. Belgian waffles taste best when made to order, but baked Belgian waffles may be kept warm in a 200°F (93°C) oven. Place in a baking pan or wrap in foil while in the oven. Waffles wrapped in foil may lose their crispness.
- Baked waffles may be frozen. Allow to cool completely, and then place in plastic food storage bag. Use waxed paper to keep waffles separated. Reheat in an oven, toaster or toaster oven when ready to use.

SUGGESTED TOPPINGS

Maple syrup, fruit syrups
Warm fruit compote, fruit sauce
Fresh berries, chopped fruit
Chopped nuts
Powdered sugar
Whipped cream
Ice cream, sorbet
Chocolate sauce
Fruited yogurt

RECIPES

QUICK 'N EASY BELGIAN WAFFLE MIX

Try this Quick 'N Easy Variety Mix batter, the results will be light & airy waffles your family will love.

- 2 cups (500 ml) waffle Variety-Baking mix**
- 2 tablespoons (25 ml) vegetable oil**
- 1 egg**
- 1 1/3 cup (325 ml) milk**

Beat all ingredients with hand mixer until smooth.

Preheat your Cuisinart™ Belgian Waffle Maker on setting #4 or preferred setting (green indicator light will be illuminated when preheated).

For best results, do not open waffle maker during cooking process. Doing so will offset the timing mechanism.

Use the measuring scoop to measure the batter and pour into the preheated waffle iron. Use a heatproof spatula to spread the batter evenly over the grids. Close lid and rotate waffle maker 180° to the right. Bake the waffles in the waffle iron until beeper indicates that the waffle is done. Rotate waffle maker 180° to the left. Remove waffle and repeat until all batter is used. Waffles may be kept warm in a low 200° F (93°C) oven. Place waffles arranged on a cookie sheet on a rack in the warm oven.

* We recommend using setting #4 to achieve a golden brown baked Belgian waffle. Adjust the browning control if you prefer lighter or darker waffles, as required.

CLASSIC BELGIAN WAFFLES

Classic Belgian waffles have a crispy outside and are soft and moist on the inside. They are often served as part of a celebration – even to celebrate something as simple as a beautiful day.

Try these waffles with your favourite syrup or a topping such as sliced fresh strawberries and freshly whipped cream.

Makes 10 waffles

- 1 1/2 cups (375 ml) water**
- 2 1/4 teaspoons (11 ml) active dry yeast (one packet)**
- 3 cups (750 ml) sifted flour**
- 1/4 teaspoon (1 ml) salt**
- 3 large eggs, separated + 1 egg white**
- 1/3 cup (75 ml) sugar**
- 1 1/2 cups (375 ml) whole milk**
- 8 tablespoons (125 ml) unsalted butter – melted and cooled**
- 2 teaspoons (10 ml) vegetable oil**
- 2 teaspoons vanilla extract**

Heat 1/2 of the water to lukewarm, 105°-110° F (41°-43°C). Dissolve the yeast in the water with a pinch of the sugar from the recipe; let stand 5 to 10 minutes, until the mixture begins to foam.

Put the flour and salt into a large bowl; stir to blend and reserve. Add the egg yolks, one of the egg whites, and remaining sugar to the yeast mixture; stir to blend. Add the remaining water, milk, melted butter, oil, and vanilla; stir until the mixture is smooth. Stir the liquid mixture into the flour mixture and beat until the mixture is smooth.

Beat the egg whites until stiff peaks form. Fold the egg whites gently into the batter. Let the batter stand for 1 hour, stirring every 15 minutes.

Preheat your Cuisinart™ Belgian Waffle Maker on setting #4 or preferred setting (green indicator light will be illuminated when preheated).

For best results, do not open waffle maker during cooking process. Doing so will offset the timing mechanism.

Use the measuring scoop to measure the batter and pour into the preheated waffle iron. Use a heatproof spatula to spread the batter evenly over the grids. Close lid and rotate waffle maker 180° to the right. Bake the waffles in the waffle iron until beeper indicates that the waffle is done. Rotate waffle maker 180° to the left. Remove waffle and repeat until all batter is used. Waffles may be kept warm in a low 200°F (93°C) oven.

Place waffles arranged on a cookie sheet on a rack in the warm oven. Serve with whipped cream, fruit, jam, powdered sugar, or warm fruit syrup.

*We recommend using setting #4 to achieve a golden brown baked Belgian waffle. Adjust the browning control if you prefer lighter or darker waffles.

Nutritional analysis per waffle:

*Calories 300 (40% from fat) • carb. 37g •
pro. 8g • fat 13g • sat. fat 7g • chol. 94mg •
sod. 104mg • calc. 61mg • fiber 1g*

GINGERBREAD BELGIAN WAFFLES

These waffles have the flavour of just baked gingerbread and are delicious served with fresh fruit or caramelized apples and pears.

Makes 6 waffles

- ½ **cup (125 ml) warm water**
- 1 **teaspoon (5 ml) granulated sugar**
- 2¼ **teaspoons (11 m) active dry yeast (1 packet)**
- 1½ **cups (375 ml) all-purpose flour**
- 1 **cup (250 ml) graham cracker crumbs**
- ¼ **cup (50 ml) granulated sugar**
- ¼ **teaspoon (1 ml) salt**
- 1 **teaspoon (5 ml) ground ginger**
- ½ **teaspoon (2 ml) finely chopped lemon zest**
- 2 **cups (500 ml) warm milk [about 105°F (41°C)]**
- 3 **large eggs, separated**
- ½ **cup (125 ml) unsalted butter, melted and cooled**
- 1 **teaspoon (5 ml) vanilla extract**

Measure water into a large bowl. Add 1 teaspoon (5 ml) granulated sugar and yeast; stir to dissolve. Let stand 10 minutes. In a separate bowl, combine the flour, graham cracker crumbs, ¼ cup (50 ml) sugar, salt, ginger, and lemon zest; stir to combine. Add the milk, egg yolks, melted cooled butter, and vanilla to the yeast mixture. Stir until smooth. Add the dry ingredients and beat until smooth, using low speed of a hand mixer. Cover with waxed paper and let stand to rise in a warm, draft-free place for 30 minutes.

Beat the egg whites until stiff, but not dry. Gently fold into the batter.

Preheat your Cuisinart™ Belgian Waffle Maker on setting #4 or preferred setting (green indicator light will be illuminated when preheated).

For best results, do not open waffle maker during cooking process. Doing so will offset the timing mechanism.

Use the measuring scoop to measure out batter, spreading evenly into waffle grids. Close lid and rotate 180° to the right and bake in the hot waffle maker until beeper sounds. Rotate waffle maker 180° to the left. Remove waffle and repeat with remaining batter. Waffles may be kept warm in a low 200°F (93°C) oven. Place waffles arranged on a cookie sheet on a rack in the warm oven. Serve with lemon curd, fruit, jam, powdered sugar, a warm fruit syrup, or whipped cream.

* We recommend using setting #4 to achieve a golden brown baked Belgian waffle. Adjust the browning control if you prefer lighter or darker waffles.

Nutritional Information per waffle:

Calories 458 (44% from fat) • carb. 23g • pro. 11g • fat 23g • sat. fat 12g • chol. 159mg • sod. 279mg • calc. 120mg • fiber 1g

GOOD NIGHT WAFFLES

Most of the mixing for these waffles is done the night before. In the morning, just mix in the eggs, vanilla extract and a pinch of baking soda while the waffle maker is heating. Leftover batter may be covered and kept in the refrigerator for up to 3 days. Heat your waffle maker in the morning, stir the batter and have a freshly baked waffle for breakfast.

Makes 6 waffles

- ½ **cup (125 ml) lukewarm [105°F (41°C)] water**
- 1 tablespoon (15 ml) granulated sugar**
- 2¼ teaspoons (11 ml) active dry yeast (1 yeast packet)**
- 2 cups (500 ml) whole milk, warmed [about 105°F (41°C)]**
- ½ **cup (125 ml) unsalted butter, melted and cooled**
- 1 teaspoon (5 ml) salt**
- 2 cups (500 ml) all-purpose flour**
- 2 large eggs, lightly beaten**
- 2 teaspoons (10 ml) vanilla extract**
- ¼ **teaspoon (1 ml) baking soda**

The night before, or at least 8 hours before baking, combine the warm water, granulated sugar and yeast. Let stand 10 minutes, until foamy. Stir in the warm milk, melted butter and salt. Beat in the flour until smooth; (this may be done using a hand mixer on low speed).

Wrap bowl tightly with plastic wrap and let stand overnight (or for 8 hours) on the countertop; do not refrigerate.

When ready to bake, preheat your Cuisinart™ Belgian Waffle Maker on setting #4 or preferred setting; (green indicator light will be illuminated when preheated).

For best results, do not open waffle maker during cooking process. Doing so will offset the timing mechanism.

While the waffle maker is heating, stir the eggs, vanilla extract and baking soda into the batter. Use measuring scoop to measure out batter. Pour onto waffle grids. Use a heat-proof spatula to spread the batter evenly over the grids. Close cover and rotate 180° to the right. Bake in the hot waffle maker until beeper sounds. Rotate 180° to the left. Remove waffle and repeat with remaining batter. Waffles may be kept warm in a low 200°F (93°C) oven. Place waffles arranged on a cookie sheet on a rack in the oven. Serve with sliced fresh fruit, jam, powdered sugar, a warm fruit syrup, or whipped cream.

* We recommend using setting #4 to achieve a golden brown baked Belgian waffle. Adjust the browning control if you prefer lighter or darker waffles.

Nutritional Information per waffle:

Calories 373 (49% from fat) • carb. 38g • pro. 10g • fat 20g • sat. fat 12g • chol. 123mg • sod. 501mg • calc. 117mg • fiber 1g

PUMPKIN NUT BELGIAN WAFFLES

These waffles taste like freshly baked pumpkin muffins and are delicious served with warm maple syrup.

Makes 6 waffles

- 1½ cups (375 ml) all-purpose flour
- 1 ounce (30 g) finely chopped walnuts or pecans (best if toasted first)
- 1 tablespoon (15 ml) cornstarch
- 1 tablespoon (15 ml) baking powder
- 1 teaspoon (5 ml) salt
- 1 teaspoon (2 ml) ground cinnamon
- ½ teaspoon (1 ml) ground ginger
- ¼ teaspoon (1 ml) freshly ground nutmeg
- ¾ cup (175 ml) pumpkin puree (canned solid pack pumpkin)
- 2 large eggs, separated
- 1 cup (250 ml) whole milk
- ¼ cup (50 ml) real maple syrup (do not use pancake syrup)
- 3 tablespoons (45 ml) unsalted butter, melted
- 1 teaspoon (5 ml) vanilla extract
- 3 large egg whites

Preheat waffle maker on setting #4.

In a large bowl, combine the flour, chopped nuts, cornstarch, baking powder, salt, cinnamon, ginger, and nutmeg. Stir to blend and reserve.

In a second bowl, combine the pumpkin puree, egg yolks, milk, maple syrup, melted butter, and vanilla extract; stir until smooth. Add the liquid ingredients to the dry ingredients and stir to blend until smooth, using a whisk.

In a clean, dry bowl, beat the egg whites until stiff peaks form. Gently fold the beaten egg whites into the batter.

Preheat your Cuisinart™ Belgian Waffle Maker on setting #4 or preferred setting; (green indicator light will be illuminated when preheated).

For best results, do not open waffle maker during cooking process. Doing so will offset the timing mechanism.

Use measuring scoop to measure out batter. Pour into waffle grids. Use a heat-proof spatula to spread the batter evenly over the grids. Close cover and rotate 180° to the right. Bake in the hot waffle maker until beeper sounds. Rotate 180° to the left. Remove waffle and repeat with remaining batter. Waffles may be kept warm in a low 200°F (93°C) oven. Place waffles arranged on a cookie sheet on a rack in the oven. Serve with warm maple syrup, powdered sugar, or whipped cream.

*We recommend using setting #4 to achieve a golden brown baked Belgian waffle. Adjust the browning control if you prefer lighter or darker waffles.

Nutritional Information per waffle:
Calories 303 (35% from fat) • carb. 40g •
pro. 10g • fat 12g • sat. fat 5g • chol. 92mg •
sod. 579mg • calc. 94mg • fiber 2g

WARRANTY

LIMITED THREE-YEAR WARRANTY

We warrant that this Cuisinart product will be free of defects in material or workmanship under normal home use for 3 years from the date of original purchase.

This warranty covers manufacturer's defects including mechanical and electrical defects. It does not cover damage from consumer abuse, unauthorized repairs or modifications, theft, misuse, or damage due to transportation or environmental conditions. Products with removed or altered identification numbers will not be covered.

This warranty is not available to retailers or other commercial purchasers or owners.

If your Cuisinart product should prove to be defective within the warranty period, we will repair it or replace it if necessary.

For warranty purposes, please register your product online at www.cuisinart.ca to facilitate verification of the date of original purchase or keep your original receipt for the duration of the limited warranty.

If the appliance should become defective within the warranty period, do not return the appliance to the store. Please contact our Customer Service Centre:

Toll-free phone number:

1-800-472-7606

Address:

Cuisinart Canada
100 Conair Parkway
Woodbridge, Ont. L4H 0L2

Email:

consumer_Canada@conair.com

Model: WAF-300C

To facilitate the speed and accuracy of your return, please enclose:

- \$10.00 for shipping and handling of the product (cheque or money order)
- Return address and phone number
- Description of the product defect
- Product date code*/copy of original proof of purchase
- Any other information pertinent to the product's return

* Product date code can be found on the underside of the base of the product. The product date code is a 4 or 5 digit number. Example, 90630 would designate year, month & day (2009, June 30th).

Note: *We recommend you use a traceable, insured delivery service for added protection. Cuisinart will not be held responsible for in-transit damage or for packages that are not delivered to us.*

To order replacement parts or accessories, call our Customer Service Centre at 1-800-472-7606.

For more information, please visit our website at www.cuisinart.ca

Cuisinart®

SAVOR THE GOOD LIFE®



Coffeemakers



Food Processors



Toasters



Rice Cookers



Grills

Cuisinart offers an extensive assortment of top quality products to make life in the kitchen easier than ever. Try some of our other countertop appliances and cookware, and Savor the Good Life®.

www.cuisinart.ca

©2010 Cuisinart
Cuisinart® is a registered trademark of Cuisinart

100 Conair Parkway
Woodbridge, Ontario L4H 0L2

Visit our Website:
www.cuisinart.ca

Consumer Call Centre E-mail:
Consumer_Canada@Conair.com

Printed in China

09CUI-C021

Any trademarks or service mark of third parties used herein are the trademarks or service marks of their respective owners.

F IB-9630-CAN