

# Cuisinart®

INSTRUCTION AND  
RECIPE BOOKLET



**SMARTPOWER™ 7-Speed Electronic Blender**

**SPB-7C Series**

For your safety and continued enjoyment of this product, always read the instruction book carefully before using.

# IMPORTANT SAFEGUARDS

When using an electrical appliance basic safety precautions should always be followed, including the following:

1. **READ ALL INSTRUCTIONS BEFORE USING.**
2. To protect against the risk of electrical shock, do not put motor base of blender in water or other liquid.
3. Close supervision is necessary when any appliance is used by or near children.
4. Unplug from outlet when not in use, before putting on or taking off parts, and before cleaning or removing contents from blender jar or container.  
**Never put hands into the blender jar or container or handle the blades with appliance plugged in.**
5. Avoid contact with moving parts.
6. Do not operate any appliance with a damaged cord or plug or after the appliance malfunctions, or is dropped or damaged in any manner. Return appliance to nearest Cuisinart service facility for examination, repair, and/or mechanical or electrical adjustment.
7. The use of attachments, including canning or ordinary jars, not recommended or sold by Cuisinart may cause fire, electrical shock, or risk of injury to persons.
8. Do not use outdoors.
9. Do not let cord hang over edge of counter or table or touch hot surfaces.
10. **Keep hands and utensils out of jar while blending to reduce the risk of severe injury to persons or damage to blender itself.** A rubber or plastic spatula may be used but must be used only when the blender is turned OFF.

11. When blender is in ON mode, and LED lights are flashing, do not touch cutting assembly, interfere with blade movement, or remove blender jar cover. Accidentally touching a speed button may activate the blender.
12. **BLADES ARE SHARP. HANDLE CAREFULLY.**
13. To reduce the risk of injury, never place cutting assembly on base without the blender jar properly attached.
14. Always operate blender with the cover in place.
15. Never leave your blender unattended while running.
16. When blending HOT liquids, remove measured pour lid (center piece of cover) to allow steam to escape.
17. Screw on locking ring firmly. Injury can result if moving blades accidentally become exposed.
18. Do not use an extension cord with this unit. Doing so may result in fire, electrical shock, or personal injury.  
**Regarding your cord set:** A longer cord has been provided so that you will have flexibility in positioning your Cuisinart® SmartPower™ Blender near an electrical outlet. Exercise care when using the longer cord to avoid entangling or tripping over the cord. The longer cord should be arranged so that it will not drape over the counter or table top, where it can be pulled on by children or tripped over. Excess cord should be stored in the cord storage area at the back of the blender base to avoid injury caused by the longer cord.
19. Wash the blender jar, cutting assembly, locking ring, and cover before first use.
20. **WARNING: TO REDUCE THE RISK OF ELECTRICAL SHOCK OR FIRE, DO NOT REMOVE THE BASE PANEL. NO USER SERVICEABLE PARTS ARE INSIDE. REPAIR SHOULD BE DONE ONLY BY AUTHORIZED PERSONNEL.**

21. **WARNING: FLASHING LIGHT INDICATES READY TO OPERATE. DO NOT TOUCH BLADES.**

## SAVE THESE INSTRUCTIONS FOR HOUSEHOLD USE ONLY NOTICE:

This appliance has a polarized plug (one prong is wider than the other). To reduce the risk of electric shock, this plug will fit into a polarized outlet only one way. If the plug does not fit fully into the outlet, reverse the plug. If it still does not fit, contact a qualified electrician. Do not modify the plug in any way.

### UNPACKING INSTRUCTIONS

Place the gift box containing your Cuisinart® SmartPower™ 7-Speed Series Electronic Blender onto a flat, sturdy surface for unpacking. Remove instruction booklet and other printed materials from top of corrugated insert. Next remove the top corrugated insert. Carefully lift the blender base from the gift box. Remove the lower corrugated insert containing the blender jar assembly. Use caution not to tip the jar when removing. Remove any additional literature from the box. To assemble the blender, follow the “Assembly” instructions on page 4 of this instruction book. Replace all corrugated inserts in the box, and save the box for repackaging. See the “Features and Benefits” section of this booklet for a listing of all blender parts.

**Before using for the first time:** Wash all parts according to the “Cleaning and Maintenance” section on page 6 of this booklet to remove any dust or residue.

## TABLE OF CONTENTS

Important Safeguards .....	p.2
Unpacking Instructions .....	p.2
Introduction .....	p.3
Features and Benefits .....	p.3
Use and Care .....	p.4
Assembly .....	p.4
Helpful Reminders .....	p.4
Operation .....	p.4
Easy Reference Guides .....	p.5
Cleaning and Maintenance .....	p.6
Do's and Don'ts .....	p.6
Recipe Tips .....	p.7
Recipes .....	p.7-15
Warranty Information .....	p.16

## INTRODUCTION

Congratulations! You have purchased a Cuisinart® SmartPower™ Electronic Blender.

The life of the party, the SmartPower™ Electronic Blender is engineered with seven speeds that crush ice, including one speed just for ice crushing. The result is delicious, professional-quality frozen drinks, from the thickest strawberry daiquiris to the most flavorful piña coladas.

The SmartPower™ Electronic Blender purées, blends, mixes, stirs, liquefies, and more. So whether you're making soup, salsa, salad dressing, or baby food, you can do it easily and quickly. No need to worry about spills or messy clean-ups, either. The SmartPower™ Electronic Blender comes with a dripless pour spout and touchpads that wipe clean in an instant.

Like all Cuisinart® appliances, the SmartPower™ Electronic Blender was designed to bring you years of enjoyment, and it is backed by a three-year limited warranty.

## FEATURES AND BENEFITS

- 1. Cover**  
is easy to use. Just press on, no turning or twisting required. Tight-fitting seal resists leakage.
- 2. 2 oz. Measured Pour Lid**  
allows you to measure and add ingredients neatly without removing the cover.
- 3. 40 oz. Glass Jar with Dripless Pour Spout**  
has a unique, sturdy, wide-mouth design and a dripless pour spout for no-mess pouring.
- 4. Leakproof Rubber Gasket (not shown)**  
holds the glass jar snugly in position for safe operation.
- 5. High-Quality Cutting Assembly with Patented Stainless Steel Blades**  
is strong enough for all blender tasks, including tough jobs, from ice crushing to chopping delicate herbs.  
**Note: Blades are sharp...handle carefully.**
- 6. Locking Ring**  
is self-aligning so that the glass blender jar slides easily into position, eliminating the frustration of twisting and turning the blender jar to lock it into place.
- 7. Heavy Duty Motor Base**  
is so sturdy and stable, it will not “walk” on your counter—even during ice crushing! The motor is strong enough to handle all blending tasks, including crushing ice without liquid, and is backed by a three-year limited warranty.
- 8. 7-Speed Touch Pad Control with Indicator Lights**  
is easy to use, read and clean. Seven speeds give you great versatility—use low speeds for delicate blending all the way up to high speeds for cheese, garlic, or lemon zest. The red LED lights clearly indicate what blender speed you are using.
- 8a. Pulse at Any Speed Button**  
allows you to pulse at any speed from high to

low, so you can blend ingredients only as much as needed.

- 8b. Ice Crush Button**  
activates the ice crushing speed. This button is pre-set to the best speed for crushed ice. However, you can crush ice at any speed.
- 9. Slip-Proof Feet**  
prevent movement during use and prevent damaging marks on countertops or tables.
- 10. Hidden Cord Storage Compartment (not shown)**  
keeps countertop safe and neat by conveniently storing excess cord.
- 11. Impact-Resistant Plastic Housing**  
is crafted of the finest quality materials to resist staining, cracking, and odors.
- 12. Innovative Cuisinart Design**  
in combination with power, performance, sturdiness, and easy cleanability, makes this blender a winner.

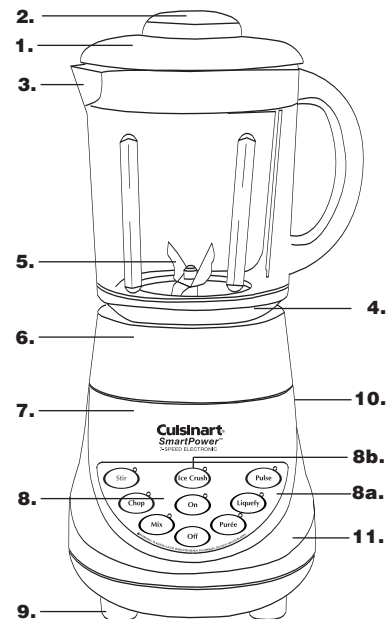

# USE AND CARE

## ASSEMBLY

To use your Cuisinart® SmartPower™ Electronic Blender, begin by assembling the blender jar.

1. Turn the blender jar (a) upside down, and place it flat on a sturdy surface.
2. Position the rubber gasket (b) on the round opening on the bottom of the blender jar.
3. Turn the cutting assembly (c) upside down, and place the blade end in the blender jar opening.

**Note: Blades are sharp...handle carefully.**

4. Secure the rubber gasket and cutting assembly into position by placing the smaller opening of the locking ring (d) on top of the cutting assembly. Engage threads by twisting the locking ring clockwise until tightened. Make sure locking ring is tightly fastened to blender jar. Once assembled, turn the blender jar right-side up.

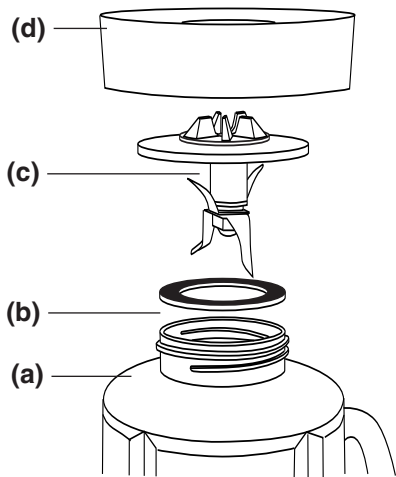

5. Push the cover onto the top of the blender jar. Push the measured pour lid into the cover.
6. Place the blender jar on the motor base so that the jar markings are facing you and the handle is positioned to one side.
7. Plug in power cord. Your blender is now ready to be used.

## HELPFUL REMINDERS

- Once the cover is in position, additional ingredients can be added during blending by simply lifting the measured pour lid, adding ingredients, and replacing the measured pour lid.
- Cover should always be in place while the unit is ON.
- **Warning:** Do not place blender jar onto base while motor is running.
- Do not twist locking ring from blender jar when removing blender jar from base. Simply lift blender jar from motor base.
- Boiling liquid or solid frozen foods (with the exception of ice cubes or 1/2" [1.3 cm] pieces of frozen fruit) should never be placed in the blender jar.
- Do not place ice, frozen foods or very cold liquids into a blender jar which has come directly from a hot dishwasher.
- Do not place very hot liquids or foods into a blender jar which has come directly from the freezer. Boiling liquids should cool for 5 minutes before being placed in blender jar.
- Follow "Cleaning and Maintenance" instructions on page 6 prior to your first use.

## OPERATION

1. Place the motor base of your Cuisinart® SmartPower™ Electronic Blender onto a flat,

sturdy surface. It is important that the surface be clean and dry. Assemble the blender by following the "Assembly" instructions. Once the jar is assembled and is in position on the motor base, plug the Cuisinart® SmartPower™ Electronic Blender into an electrical outlet.

2. Add all necessary ingredients to the blender jar, and replace the cover. You may add additional ingredients by lifting the measured pour lid and dropping ingredients through the fill area. Replace the measured pour lid after adding ingredients. **Do not place hands into blender jar with blender plugged in.**

**Note:** Add liquid ingredients first, then follow with solid ingredients. This will provide more consistent blending and prevent unnecessary stress on the motor.

**Tip:** Liquid ingredients can be measured in the measured pour lid using the measurement marking. Solid ingredients can be added by simply dropping them through the fill area into the blender jar. Replace the measured pour lid after adding ingredients.

3. **TO START BLENDING:** press the ON button. The red ON LED light will flash, indicating that the blender is turned on but no speed has been selected.

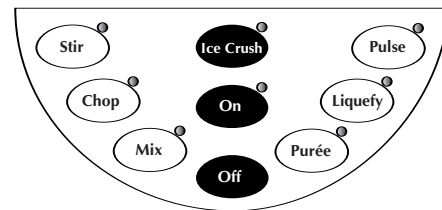

4. **PRESS THE DESIRED BLENDING SPEED:** both the ON indicator light and the activated speed indicator light will glow. The blender will now be functioning at the desired speed. It is possible to switch speeds without pressing the OFF button, by simply pushing the next desired speed button.

5. **TO STOP THE BLENDING PROCESS:** re-press the activated speed button. The blending process will stop. The red ON indicator light will continue to flash to let you know that the blender is still ON and can be reactivated by pushing the desired speed button. The blender can be completely deactivated and stopped from any speed by pushing the OFF button. You will need to press the ON button again to continue blending. As an added safety feature the blending process can also be stopped by pushing any two speed buttons simultaneously. This procedure will turn the blender OFF. To reset the blender press the OFF button then press the ON button.
6. **PULSE MODE:** while the blender is turned ON, you can create a burst of power for quick, efficient blending by activating the PULSE function. To do so, first push the PULSE button, which will cause the PULSE indicator light to flash. Next, push and release the desired speed button. Repeat as desired. You determine the duration of each pulse. While pulsing, all indicator lights (the ON, the PULSE, and the desired SPEED) will glow. The PULSE function can be used to break apart larger pieces of food or to control the texture of food when chopping. The PULSE function is also effective in starting the blending process when you do not want continuous power, or when processing items which do not require an extended amount of blending.
7. **TO CRUSH ICE:** the SmartPower™ Electronic Blender motor is strong enough to crush ice without liquid at any speed; however, for your convenience we have preset the best speed for ice crushing. To give you greater control, the ICE CRUSH function automatically operates as a PULSE function. To crush ice, place ice cubes in the blender jar, and place the cover and the measured pour lid on the blender jar. Press the ON button. Press the ICE CRUSH button in short pulses until ice

## QUICK REFERENCE GUIDE

To Activate Blender  
To Begin Blending  
To Change Speeds  
To Pulse

To Crush Ice

To Stop Blending (and Deactivate Blender)  
To Stop Blending (in Pulse or ICE CRUSH Mode)  
To Stop Blending in Stir, Chop, Mix, Purée, or Liquefy Mode

Press ON- The blender is in ON Mode.  
Press desired Speed Button.  
Press desired Speed Button.  
In ON mode press PULSE, then press and release desired speed button as needed.  
In ON mode, press and release ICE CRUSH Button as needed.  
Press OFF Button.  
Release button.  
  
Press Speed Button again. This will return the blender to ON mode. Press OFF Button to turn blender OFF.

## SPEED SELECTION GUIDE

Refer to this guide to choose the best speed for your desired result.

Ingredient/Recipe	Speed	Result
Reconstituting frozen orange juice concentrate	Stir	Smooth and full-bodied
Mayonnaise	Stir	Thick and creamy
Salad dressings	Stir	Desired consistency
Nuts	Chop	Coarse to fine
Whipping cream	Mix	Thick topping
Bread Crumbs	Mix	Uniformly fine
Health drinks	Liquefy	Smooth and creamy
Frozen cocktails	Liquefy	Thick and slushy
Grinding hard cheese	Liquefy	Coarse to fine
Spices	Liquefy	Coarse to fine
Grating citrus zest	Purée	Uniformly fine
Milk shakes	Purée	Smooth and creamy
Baby food	Purée	Smooth and creamy
Ice	Ice Crush	Snowy

is crushed to desired consistency. See the "Recipe Tips" section on page 7 for more details.

8. **TO DISLODGE FOOD:** use a rubber or plastic spatula to help remove food lodged around the cutting assembly. **DO NOT USE SPATULA UNTIL YOU HAVE TURNED THE BLENDER OFF.** Replace the cover and measured pour lid and continue blending, if necessary. Make sure spatula is not inside the blender jar before blending.
9. **WHEN FINISHED BLENDING:** press the OFF button, and unplug the blender from the electrical outlet. Never remove the blender jar from the base until pressing the OFF button. Do not twist locking ring from blender jar when removing jar from motor base. Simply lift blender jar from motor base. **Do not place hands into blender jar with blender plugged in.**

## CLEANING AND MAINTENANCE

Always unplug your Cuisinart® SmartPower™ Electronic Blender from the electrical outlet before cleaning. The blender is made of corrosion-resistant parts which are easy to clean. Before first use and after every use, clean each part thoroughly. Periodically check all parts before reassembly. If any part is damaged or blender jar is chipped or cracked, **DO NOT USE BLENDER.**

Remove the blender jar from the motor base by lifting straight up and away. Twist off the locking ring by turning counter-clockwise. Remove the cutting assembly and rubber gasket. Wash in warm soapy water, rinse and dry thoroughly. Place the locking ring in the upper rack of the dishwasher or wash in warm water.

**CAUTION:** Handle the cutting assembly carefully. It is SHARP and may cause injury. Do not attempt to remove blades from cutting assembly.

Remove the blender jar cover and the measured pour lid. Wash in warm, soapy water; rinse and dry thoroughly, or place in upper rack of a

dishwasher. The blender jar must be washed in warm soapy water and rinsed and dried thoroughly. The blender jar can also be placed upside down in a dishwasher.

Finally, wipe the motor base clean with a damp cloth to remove any residue and dry thoroughly. Never submerge the motor base in water or other liquid or place in a dishwasher.

**Tip:** You may wish to clean your blender cutting assembly as follows: Squirt a small amount of dishwashing liquid into assembled blender jar and fill halfway with warm water. Run on STIR for 15 seconds. Repeat using clean tap water. Empty blender jar and carefully disassemble parts. Wash cutting assembly, gasket and locking ring in warm, soapy water. Rinse and dry all parts thoroughly.

## DO'S AND DON'TS WHEN USING YOUR BLENDER

### DO:

- Make sure the electrical outlet is rated at the same voltage as that stated on the bottom of the blender motor base.
- Always use the blender on a clean, sturdy and dry surface.
- **Always add liquid ingredients to the blender jar first, then add remaining ingredients. This will ensure that ingredients are uniformly mixed.**
- Cut most foods into cubes approximately 1/2" (1.3 cm) to 1" (2.5 cm) to achieve a more uniform result. Cut all cheeses into pieces no larger than 1/2" (1.3 cm).
- Use the measured pour lid to measure liquid ingredients such as alcohol. Replace measured pour lid after ingredients have been added.
- Use a rubber or plastic spatula as needed only when the blender is turned OFF. Never use metal utensils, as damage may occur to the blender jar or cutting assembly.

- Place cover on firmly. Always operate the blender with the cover on.
- Make sure locking ring is tightly attached to blender jar.
- Always remove locking ring, cutting assembly, and rubber gasket before cleaning.
- When scraping the blender jar with a spatula, remove the food from the sides of the blender jar and place it in the center of the blender jar, over the cutting assembly.
- When chopping fresh herbs, garlic, onion, zest, bread crumbs, spices, etc...make sure the blender jar and cutting assembly are completely dry.
- If food tends to stick to the sides of the blender jar when blending, pulse in short bursts.
- Pulses should be short bursts. Space the pulses so the blades stop rotating between pulses.

### DON'T:

- Don't store food or liquids in your blender jar.
- Don't place cutting assembly and locking ring onto motor base without the blender jar attached.
- Blender will not mash potatoes, knead heavy dough, or beat egg whites.
- Don't remove blender jar while unit is ON. Keep the blender jar cover on the blender jar while blending.
- Don't twist locking ring from blender jar when removing blender jar from motor base. Simply lift blender jar from motor base.
- Don't overprocess foods. Blender will achieve most desired results in seconds, not minutes.
- Don't overload blender. If the motor stalls, turn the blender OFF immediately, unplug the unit, and remove a portion of the food, then continue.

- Don't use any utensil inside the blender jar while the motor is ON.
- Don't use any container or accessories not recommended by Cuisinart. Doing so may result in injury.
- Don't place hands inside the blender jar when blender is plugged in.
- Don't add boiling liquids or frozen foods (except ice cubes or 1/2" pieces of frozen fruit) to glass blender jar. Boiling liquids should cool for 5 minutes before being placed in blender jar.

## RECIPE TIPS

You'll find many easy ways to prepare savory, healthful meals with your Cuisinart® SmartPower™ Electronic Blender. The simple recipes that follow include some old Cuisinart favorites as well as some creative combinations that are sure to please your friends and family. Thanks to the superior ice crushing power of the SmartPower™ Electronic Blender you'll also be able to make delicious frozen drinks.

## RECIPE TIPS:

### Chopping Nuts

Pulse 1/2 cup (125 ml) of nuts (shells removed) on Chop 4-5 times. Turn blender OFF; scrape blender jar with spatula. Turn blender ON and pulse on Chop 2-3 times. Turn blender OFF. Pulse fewer times for more coarsely chopped results. For best results, process no more than 1 cup at a time.

### Bread, Cookie or Cracker Crumbs

For best results, use day-old bread (drier bread works best). Break bread slices into 1/2" (1.3 cm) pieces, and process no more than 1 cup (250 ml) of pieces at a time on **Mix** for 5-10 seconds. Crackers and cookies should also be broken into 1/2" (1.3 cm) pieces; process 1 cup (250 ml) at a time on **Mix** for 10-15 seconds. **Turn blender OFF.**

### Crushing Ice

Add up to 12 large ice cubes to blender jar. Press the **Ice Crush Button**, using short bursts, 11-12

times or until cubes are the consistency of snow. **Turn blender OFF.** Pulse fewer times if coarsely chopped ice is desired.

### Grating Citrus Zest

For best results, blender jar and cutting assembly must be clean and dry. Remove zest from fruit in strips (using vegetable peeler). Use no more than 8 strips at a time (zest of one medium lemon). Pulse on **Purée** 4-5 times. Turn blender OFF and scrape blender jar with a spatula. Turn blender ON and blend on **Purée** for 10-15 seconds. **Turn blender OFF.**

### Grinding Hard Cheese

Cut cheese into 1/2" (1.3 cm) pieces. Blend on **Liquefy** for 30 seconds. **Turn blender OFF.** For best results, grind no more than 3 ounces (90 g) of cheese at a time.

### Grinding Spices

For best results, blender jar and cutting assembly must be clean and dry. Add 1/4-1/2 cup (50-125 ml) of spices/seeds/peppercorns to blender jar. Blend on **Liquefy** for 30-35 seconds. **Turn blender OFF.**

### Whipping Cream

Whip 1 cup (250 ml) of cream (whipping or heavy cream) at a time. Blend on **Mix**, and process for 45 seconds or until creamy and smooth. If making sweetened cream, add sugar after 10 seconds. **Turn blender OFF.** Makes about 1 cup (250 ml).

### Puréeing Sun-Dried Tomatoes

Rehydrate 1 ounce (30 g) of tomatoes in 1 cup (250 ml) boiling water. Allow to sit for 10 minutes or until softened. Add tomatoes and water to blender jar. Cover and pulse on **Liquefy** 5 times; then run continuously on **Liquefy** for 15-20 seconds. **Turn blender OFF.** Drain in fine strainer if desired. Makes about 1/2 cup (125 ml) of puréed tomatoes.

## RECIPES

Before following any of these Cuisinart recipes make sure the SmartPower™ Electronic Blender is properly assembled. Follow the "Assembly" directions on page 4 of this instruction booklet for correct blender assembly procedure.

## FROZEN BEVERAGES

### FROZEN CRANBERRY-ORANGE MIMOSAS

Makes ten servings

- 1 cup (250 ml) cranberry juice cocktail, chilled
- 1 cup (250 ml) orange juice, chilled
- 1-1/2 cups (375 ml) ice cubes
- 1 bottle (750 ml) brut champagne, chilled

Place cranberry juice, orange juice, and ice cubes in blender jar in order listed. Place cover on blender jar. Turn blender ON and process on **Liquefy** until thick and frothy, about 30-40 seconds. **Turn blender OFF.**

Pour 1/3 cup juice mixture into each champagne glass. Top with chilled champagne. Serve immediately.

Nutritional analysis per serving:

Calories 32 (0% from fat) • carbo. 8g • prot. 0g • fat 0g sat. fat 0g • chol. 0mg • sod. 14mg

### FROZEN FRUIT DAIQUIRI

Makes five 4-ounce (125 ml) servings

- 4 ounces (125 ml) frozen limeade concentrate, thawed
- 3 ounces (120 ml) light rum
- 2 cups (500 ml) ice cubes
- 1 cup (250 ml) ripe fruit, cut into 1" (2.5 cm) pieces (strawberries, bananas, peaches)

Place ingredients in blender jar in order listed. Place cover on blender jar. Turn blender ON and process on **Liquefy** until slushy, about 45-50 seconds. **Turn blender OFF.** Serve immediately.

Nutritional analysis per serving:  
Calories 90 (0% from fat) • carbo. 13g • prot. 0g • fat 0g  
sat. fat 0g • chol. 0mg • sod. 3mg

### FROZEN DAIQUIRI

Makes four 4-ounce (125 ml) servings

- 4 ounces (125 ml) frozen limeade concentrate, thawed
- 3 ounces (120 ml) light rum
- 2 cups (500 ml) ice cubes

Place ingredients in blender jar in order listed. Place cover on blender jar. Turn blender ON and process on **Liquefy** until slushy, about 45-50 seconds. **Turn blender OFF.** Serve immediately.

Nutritional analysis per serving:  
Calories 105 (0% from fat) • carbo. 14g • prot. 0g • fat 0g  
sat. fat 0g • chol. 0mg • sod. 4mg

### RUM AND ORANGE FREEZE

Makes four 4-ounce (125 ml) servings

- 1 cup (250 ml) orange juice
- 1-1/2 ounces (45 ml) dark rum
- 1 cup (250 ml) ice cubes

Place ingredients in blender jar in order listed. Place cover on blender jar. Turn blender ON and process on **Liquefy** until slushy, about 30 seconds. **Turn blender OFF.** Serve immediately.

Nutritional analysis per serving:  
Calories 45 (0% from fat) • carbo. 6g • prot. 0g • fat 0g  
sat. fat 0g • chol. 0mg • sod. 2mg

### MARGARITA

Makes four 4-ounce (125 ml) servings

- 1/2 cup (125 ml) lime juice

- 4 ounces (125 ml) tequila
- 1 tablespoon (15 ml) sugar
- 2 cups (500 ml) ice cubes

Place ingredients in blender jar in order listed. Place cover on blender jar. Turn blender ON and process on **Liquefy** until slushy, about 45-60 seconds. **Turn blender OFF.** Serve immediately.

Nutritional analysis per serving:  
Calories 94 (0% from fat) • carbo. 6g • prot. 0g • fat 0g  
sat. fat 0g • chol. 0mg • sod. 4mg

### PIÑA COLADA

Makes two 6-ounce (175 ml) servings

- 1/2 cup (125 ml) unsweetened pineapple juice
- 2 ounces (50 ml) sweetened cream of coconut
- 2 ounces (50 ml) dark rum
- 1 cup (250 ml) ice cubes

Place ingredients in blender jar in order listed. Place cover on blender jar. Turn blender ON and process on **Liquefy** until slushy, about 45-50 seconds. **Turn blender OFF.** Serve immediately.

Nutritional analysis per serving:  
Calories 143 (25% from fat) • carbo. 10g • prot. 1g • fat 4g  
sat. fat 2g • chol. 11mg • sod. 17mg

### MILK SHAKES/FRAPPEs

#### ORANGE CREAMSICLE

Makes one 12-ounce (375 ml) serving

- 3/4 cup (175 ml) skim milk
- 2 scoops (8 ounces/250 ml) orange sherbet
- 2 tablespoons (25 ml) instant non-fat dry milk
- 1/2 teaspoon (2 ml) vanilla extract

Place ingredients in order listed in blender jar. Place cover on blender jar. Turn blender ON and process on **Liquefy** until smooth, about 30 seconds. **Turn blender OFF.** Serve immediately.

Nutritional analysis per serving:  
Calories 396 (9% from fat) • carbo. 76g • prot. 14g • fat 4g  
sat. fat 3g • chol. 20mg • sod. 265mg

### CHOCOLATE MILK SHAKE

Makes two 8-ounce (250 ml) servings

- 1 cup (250 ml) 2% milk
- 1 scoop (4 ounces/125 ml) vanilla ice cream
- 2 tablespoons (25 ml) chocolate syrup

Place ingredients in blender jar in order listed. Place cover on blender jar. Turn blender ON and process on **Purée** until smooth and creamy, about 25-30 seconds. **Turn blender OFF.** Serve immediately.

Nutritional analysis per serving:  
Calories 243 (41% from fat) • carbo. 29g • prot. 7g  
fat 11g • sat. fat 7g • chol. 34mg • sod. 127mg

---

#### Variation:

For a strawberry milk shake, substitute strawberry syrup and strawberry ice cream.

---

### CAPPUCCINO SHAKE

Makes four 8-ounce (250 ml) servings

- 1 cup (250 ml) espresso coffee or strong coffee
- 1/2 cup (125 ml) half-and-half
- 1/4 cup (50 ml) sugar\*
- 1 cup (250 ml) ice cubes  
ground cinnamon

Place all ingredients except cinnamon in blender jar in order listed. Place cover on blender jar. Turn blender ON and process on **Liquefy** until smooth, about 25-30 seconds. **Turn blender OFF.** Pour into glasses, and sprinkle with cinnamon. Serve immediately.

\* Use less sugar (about 3 tablespoons) if a less sweet beverage is desired.

Nutritional analysis per serving:  
Calories 87 (31% from fat) • carbo. 14g • prot. 1g • fat 3g  
sat. fat 2g • chol. 11mg • sod. 14mg

---

**Variation:**

Pour mixture into ice cube trays, and freeze until solid. Place in blender jar, and crush, using Ice Crush to make a refreshing frozen dessert.

---

**ICE CREAM SODA**

Makes two 12-ounce (375 ml) servings

- 1 cup (250 ml) 2% milk
- 1 scoop (4 ounces/125 ml) vanilla ice cream
- 2 tablespoons (25 ml) chocolate syrup
- 1 cup (250 ml) ginger ale

Place milk, ice cream, and chocolate syrup in blender jar in order listed. Place cover on blender jar. Turn blender ON and process on **Purée** until smooth and creamy, about 40-45 seconds. **Turn blender OFF.** Divide ginger ale into two tall glasses (about 14-16 ounces/400-450 ml each). Add ice cream mixture, and stir gently. Serve immediately.

Nutritional analysis per serving:  
Calories 287 (34% from fat) • carbo. 40g • prot. 7g  
fat 11g • sat. fat 7g • chol. 34mg • sod. 136mg

**MOCHA SHAKE**

Makes one 12-ounce (375 ml) serving

- 1 teaspoon (5 ml) instant coffee crystals
- 1 tablespoon (15 ml) hot water
- 1/2 cup (125 ml) 2% milk
- 2 scoops (8 ounces/250 ml) vanilla low-fat frozen yogurt or vanilla ice milk.
- 2 tablespoons (25 ml) chocolate syrup

Dissolve coffee crystals in hot water, and place in blender jar. Add remaining ingredients in order listed. Place cover on blender jar. Turn blender ON and process on **Purée** until smooth, about 25-30 seconds. **Turn blender OFF.** Serve immediately.

Nutritional analysis per serving:  
Calories 479 (28% from fat) • carbo. 71g • prot. 15g  
fat 15g • sat. fat 7g • chol. 43mg • sod. 255mg

**SMOOTHIES****ALL-FRUIT SMOOTHIE**

Makes six 6-ounce (175 ml) servings

- 1/4 cup (50 ml) orange juice
- 1 cup (250 ml) cantaloupe, cut into 1" (2.5 cm) pieces
- 1 cup (250 ml) green or red seedless grapes
- 1 cup (250 ml) canned pineapple chunks, drained
- 1 cup (250 ml) navel orange segments, cut into 1" (2.5 cm) pieces
- 1 cup (250 ml) strawberries, cut into 1" (2.5 cm) pieces
- 1 medium banana, cut into 1" (2.5 cm) pieces
- 1 cup (250 ml) ice cubes

Layer the ingredients in the blender jar in the order listed. Do not pack fruit tightly into blender jar. Place cover on blender jar. Turn blender ON and process on **Liquefy** until smooth, about 30-40 seconds. **Turn blender OFF.**

**Note:** The riper the fruit, the sweeter the smoothie.

Nutritional analysis per serving:  
Calories 92 (0% from fat) • carbo. 22g • prot. 1g • fat 0g  
sat. fat 0g • chol. 0mg • sod. 5mg

**BANANA-PINEAPPLE FREEZE**

Makes two 8-ounce (250 ml) servings

- 1 cup (250 ml) unsweetened pineapple juice
- 1/2 medium banana, cut into 1" (2.5 cm) pieces
- 1/4 cup (50 ml) instant non-fat dry milk
- 1 cup (250 ml) ice cubes

Place ingredients in blender jar in order listed. Place cover on blender jar. Turn blender ON and process on **Liquefy** until smooth, about 25-30 seconds. **Turn blender OFF.** Serve immediately.

Nutritional analysis per serving:  
Calories 152 (0% from fat) • carbo. 32g • prot. 6g • fat 0g  
sat. fat 0g • chol. 3mg • sod. 87mg

**DIPS/SPREADS/APPETIZERS**

For best results when blending fresh herbs, garlic etc...the herbs, blender jar and cutting assembly must be dry and clean.

**HUMMUS**

Makes 2-1/4 cups (550 ml)

- 1/2 cup (125 ml) lemon juice
- 2 cups (500 ml) canned, cooked garbanzo beans, drained, reserve 2 tablespoons liquid
- 4 medium garlic cloves, peeled, quartered
- 4 tablespoons (50 ml) tahini (optional)
- 1-1/2 tablespoons (25 ml) olive oil
- 1/4 tablespoon (5 ml) chopped parsley
- 2 teaspoons (10 ml) salt

Place lemon juice, garbanzo beans, reserved liquid, garlic, tahini, olive oil and salt in blender jar in order listed. Place cover on blender jar. Turn blender ON and process on **Liquefy** until smooth, about 20 seconds. **Turn blender OFF.** Scrape blender jar with a spatula. Turn blender ON and process an additional 25-30 seconds until smooth. **Turn blender OFF.** Transfer to a serving dish, and sprinkle with parsley. Serve at room temperature.

Nutritional analysis per tablespoon (15 ml):  
Calories 40 (27% from fat) • carbo. 6g • prot. 1g  
fat 1g • sat. fat 0g • chol. 0mg • sod. 69mg

**MINTED YOGURT SAUCE**

Makes two cups

- 2 cups (500 ml) low-fat vanilla yogurt
- 1 tablespoon (15 ml) sugar
- 3 tablespoons (45 ml) fresh mint leaves

Place ingredients in blender jar. Place cover on blender jar. Turn blender ON and process on **Purée** until well blended, about 10-15 seconds. **Turn blender OFF.** Serve chilled with fresh fruit.

Nutritional analysis per tablespoon (15 ml):  
Calories 16 (0% from fat) • carbo. 3g • prot. 1g • fat 0g

sat. fat 0g • chol. 1mg • sod. 8mg

---

### Variation:

Substitute fruit-flavored yogurt.

---

## MEXICAN SALSA CRUDA

Makes two cups (500 ml)

- 1 28-ounce (800 ml) can plum tomatoes, drained
- 1/4 cup (50 ml) cilantro leaves
- 2 jalapeño peppers, halved, seeded, cut into 1/2" (1.3 cm) pieces
- 1 small onion, peeled, cut into 1/2" (1.3 cm) pieces
- 1 teaspoon (5 ml) fresh lime juice
- 1 teaspoon (5 ml) salt

Place ingredients in blender jar in order listed. Place cover on blender jar. Turn blender ON and pulse on **Mix** 5-6 times until coarsely chopped. **Turn blender OFF.** Allow to sit for 1-2 hours to develop flavor. Drain before serving if a thicker salsa is desired.

Nutritional analysis per tablespoon (15 ml):

Calories 8 (0% from fat) • carbo. 2g • prot. 0g • fat 0g  
sat. fat 0g • chol. 0mg • sod. 76mg

## SPICY CRABMEAT DIP

Makes 1-3/4 (425 ml) cups

- 1/3 cup (75 ml) milk
- 1 cup (250 ml) low-fat sour cream
- 1/4 cup (50 ml) low-fat mayonnaise
- 1 can (6 ounces) crabmeat, drained (about 3/4 cup/175 ml)
- 1 tablespoon (15 ml) fresh chopped chives
- 1-1/2 teaspoons prepared (7 ml) horseradish
- 1/4 teaspoon (1 ml) ground white pepper

Place ingredients in blender jar in order listed. Place cover on blender jar. Turn blender ON and process on **Purée** until well blended, about 20-25 seconds. **Turn blender OFF.** Scrape blender jar with a spatula. Turn blender ON and process an additional 10 seconds until well combined. Refrigerate 1-2 hours before serving to develop flavor.

Nutritional analysis per tablespoon (15 ml):

Calories 34 (53% from fat) • carbo. 2g • prot. 2g • fat 2g  
sat. fat 1g • chol. 15mg • sod. 91mg

## CHUNKY GUACAMOLE

Makes 1-1/2 cups (375 ml)

- 1/4 cup (50 ml) fresh cilantro leaves
- 1 medium garlic clove, peeled, quartered
- 1 small scallion, trimmed, cut into 1" (2.5 cm) pieces
- 1/2 small green chili, seeded and quartered
- 1/4 teaspoon (1 ml) salt
- 1/8 teaspoon (0.5 ml) chili powder
- 1/2 cup (125 ml) non-fat plain yogurt
- 2 tablespoons (25 ml) fresh lemon juice
- 1 small plum tomato, cut into 1/2" (1.3 cm) pieces
- 2 small ripe avocados, peeled, pits removed, cut into 1/2" (1.3 cm) pieces

Place cilantro, garlic, scallion, chili, salt, and chili powder in blender jar. Place cover on blender jar. Turn blender ON and pulse on **Stir** until coarsely chopped, about 5-6 times. Add yogurt, lemon juice, and tomato pieces. Pulse on **Stir** until coarsely chopped (about 5 times), then run continuously on **Stir** until combined, about 10 seconds. Add avocado pieces, and pulse on **Stir** to combine, about 10 times. **Turn blender OFF.** Scrape blender jar with a spatula. Turn blender ON. Run continuously on **Stir** until combined, but still chunky, about 10 seconds. **Turn blender OFF.**

**Tip:** To prevent browning, bury the pit in the center of the mixture for serving or storage.

Nutritional analysis per tablespoon (15 ml):

Calories 39 (69% from fat) • carbo. 2g • prot. 1g • fat 3g  
sat. fat 0g • chol. 0mg • sod. 30mg

## SAUCES/DRESSINGS/ VINAIGRETTES

### CHOCOLATE SAUCE

Makes six tablespoons (90 ml)

- 3 1-ounce (30 g) squares semisweet chocolate, each broken into 8 pieces
- 1-1/2 teaspoons (7 ml) sugar
- 1/4 cup (50 ml) boiling water, cooled for 5 minutes

Place chocolate and sugar in blender jar. Place cover on blender jar. Turn blender ON and process on **Liquefy** until coarsely chopped, about 10-15 seconds. Add water, and process on **Liquefy** until smooth, about 10 seconds. **Turn blender OFF.** Serve immediately or cool and refrigerate in an airtight container for up to 4 weeks. Reheat before serving.

Nutritional analysis per tablespoon (15 ml):

Calories 85 (53% from fat) • carbo. 9g • prot. 1g • fat 5g  
sat. fat 3g • chol. 0mg • sod. 0mg

### NON-FAT HERBED SALAD DRESSING

Makes one cup (250 ml)

- 1 cup (250 ml) fresh parsley
- 1 small shallot, peeled and quartered
- 1-1/2 tablespoons (25 ml) fresh dill weed
- 1 tablespoon (15 ml) celery seed
- 1 tablespoon (15 ml) fresh cilantro
- 1 tablespoon (15 ml) fresh oregano
- 1/4 teaspoon (1 ml) white pepper
- 1/4 teaspoon (1 ml) salt

- 1/3 cup (75 ml) skim milk
- 1/2 cup (125 ml) non-fat yogurt
- 1 tablespoon (15 ml) fresh lemon juice
- 1 tablespoon (15 ml) Dijon mustard
- 1 tablespoon (15 ml) balsamic vinegar

Place parsley, shallot, dill, celery seed, cilantro, oregano, pepper, and salt in the blender jar. Place cover on blender jar. Turn blender ON and pulse on **Stir** until coarsely chopped, about 5 times. **Turn blender OFF.** Scrape blender jar with a spatula. Turn blender ON and pulse on **Stir** 5 times. Add milk, yogurt, lemon juice, mustard, and vinegar in order listed; process on **Stir** until well blended, about 15-20 seconds. **Turn blender OFF.** Store in the refrigerator for up to 2 weeks in an airtight container.

Nutritional analysis per tablespoon (15 ml):  
Calories 12 (0% from fat) • carbo. 2g • prot. 1g • fat 0g  
sat. fat 0g • chol. 0mg • sod. 71mg

### TOMATO SAUCE

Makes four 2-ounce (60 ml) servings

- 1 28-ounce (800 ml) can Italian plum tomatoes, drained
- 2 medium shallots, peeled, cut into 1/2" (1.3 cm) pieces
- 1/2 teaspoon (2 ml) dried oregano
- 1/2 teaspoon (2 ml) salt
- 1/2 teaspoon (2 ml) sugar

Place ingredients in blender jar in order listed. Place cover on blender jar. Turn blender ON and process on **Purée** until coarsely chopped, about 10-15 seconds. **Turn blender OFF.** Transfer to skillet or saucepan; simmer over medium-low heat, stirring occasionally, until thick, about 20-30 minutes.

**Note:** Purée 20-25 seconds for a smoother sauce.

Nutritional analysis per serving:  
Calories 57 (16% from fat) • carbo. 10g • prot. 2g • fat 1g  
sat. fat 0g • chol. 0mg • sod. 312mg

### PESTO SAUCE

Makes eight 1-ounce (30 ml) servings

- 3 ounces (90 g) Parmesan cheese, cut into 1/2" (1.3 cm) pieces
- 3 small garlic cloves, peeled and quartered
- 3/4 cup (175 ml) olive oil
- 2 cups (500 ml) fresh basil leaves, loosely packed
- 1/4 cup (50 ml) pine nuts

Place cheese in blender jar. Place cover on blender jar. Turn blender ON and blend on **Liquefy** until finely ground, about 30 seconds. Reserve. Add garlic, and blend on **Liquefy** until minced, about 15 seconds. Add remaining ingredients in order listed and reserved cheese; blend on **Liquefy** until combined, about 45-50 seconds. **Turn blender OFF.** Pesto may be stored in refrigerator, in an airtight container, for up to 5 days. It also freezes well.

Nutritional analysis per serving:  
Calories 262 (89% from fat) • carbo. 2g • prot. 5g • fat 26g  
sat. fat 5g • chol. 8mg • sod. 202mg

### RASPBERRY SAUCE

Makes eight 1-ounce (30 ml) servings

- 12 ounces (340 g) frozen raspberries, thawed, at room temperature (about 1-1/2 cups/375 ml)
- 1 tablespoon (15 ml) sugar

Place raspberries and sugar in blender jar. Place cover on blender jar. Turn blender ON and pulse 5 times on **Purée**, then run continuously on **Purée** until smooth, about 10 seconds. **Turn blender OFF.** Strain mixture through a fine sieve. Store in an airtight container in the refrigerator. Serve over ice cream or cheesecake.

Nutritional analysis per serving:  
Calories 52 (0% from fat) • carbo. 13g • prot. 0g • fat 0g  
sat. fat 0g • chol. 0mg • sod. 0mg

### CLASSIC MAYONNAISE

Makes 2/3 cup (150 ml)

- 2 large egg yolks
- 2 tablespoons (25 ml) red wine vinegar
- 1 tablespoon (15 ml) vegetable oil
- 1 teaspoon (5 ml) dry mustard
- 1/8 teaspoon (0.5 ml) ground white pepper
- 1/8 teaspoon (0.5 ml) salt
- 2/3 cup (150 ml) vegetable oil

Place egg yolks, vinegar, 1 tablespoon vegetable oil, mustard, pepper and salt in the blender jar. Place cover on blender jar. Turn blender ON and process on **Stir** until blended, about 5 seconds. With machine running on **Stir**, lift the measured pour lid, and add the 2/3 cup oil in a slow, steady stream. Hold the measured pour lid over the opening while adding the oil to prevent splatter. The mayonnaise will thicken and emulsify as the oil is added. **Turn blender OFF.** For a thicker mayonnaise chill for one hour before serving. Store in an airtight container in the refrigerator.

Nutritional analysis per tablespoon (15 ml):  
Calories 66 (97% from fat) • carbo. 0g • prot. 1g • fat 7g  
sat. fat 1g • chol. 17mg • sod. 22mg

### LOW-FAT BLUE CHEESE DRESSING

Makes one cup (250 ml)

- 1 cup (250 ml) fresh parsley
- 1/3 cup (75 ml) skim milk
- 1/2 cup (125 ml) non-fat yogurt
- 2 ounces (60 g) blue cheese, in 1/2" (1.3 cm) pieces
- 1 tablespoon (15 ml) fresh lemon juice
- 1 tablespoon (15 ml) balsamic vinegar
- 1/4 teaspoon (1 ml) ground white pepper
- 1/4 teaspoon (1 ml) salt

Place parsley in the blender jar. Place cover on blender jar. Turn blender ON and pulse on **Stir**

until coarsely chopped, about 5 times. Add remaining ingredients in order listed, and blend on **Stir** until combined, about 15-20 seconds.

**Turn blender OFF.** Store in the refrigerator for up to 2 weeks in an airtight container.

Nutritional analysis per tablespoon (15 ml):

Calories 17 (53% from fat) • carbo. 1g • prot. 1g • fat 1g  
sat. fat 1g • chol. 3mg • sod. 96mg

### **CHOLESTEROL-FREE MAYONNAISE**

Makes 2/3 cup (150 ml)

- 1/2 cup (125 ml) liquid egg substitute
- 2 tablespoons (25 ml) red wine vinegar
- 1 tablespoon (15 ml) vegetable oil
- 1 teaspoon (5 ml) dry mustard
- 1/8 teaspoon (0.5 ml) ground white pepper
- 1/8 teaspoon (0.5 ml) salt
- 2/3 cup (150 ml) vegetable oil

Place egg substitute, vinegar, 1 tablespoon (15 ml) vegetable oil, mustard, pepper and salt in the blender jar. Place cover on blender jar. Turn blender ON and process on **Stir** until blended, about 5 seconds. With machine running on **Stir**, lift the measured pour lid, and add the 2/3 cup oil in a slow, steady stream. Hold the measured pour lid over the opening while adding the oil to prevent splatter. The mayonnaise will thicken and emulsify as the oil is added. **Turn blender OFF.** For a thicker mayonnaise, chill for one hour before serving. Store in an airtight container in the refrigerator.

Nutritional analysis per tablespoon (15 ml):

Calories 66 (94% from fat) • carbo. 0g • prot. 1g • fat 7g  
sat. fat 1g • chol. 0mg • sod. 22mg

### **CLASSIC VINAIGRETTE**

Makes 3/4 cup (175 ml)

- 1 small garlic clove, peeled and quartered
- 3/4 cup (175 ml) vegetable oil
- 1/4 cup (50 ml) red wine vinegar

- 1 tablespoon (15 ml) Dijon mustard
- 1/8 teaspoon (0.5 ml) ground white pepper
- 1/8 teaspoon (0.5 ml) salt

Place garlic in blender jar. Place cover on blender jar. Turn blender ON and process on **Liquefy** until finely chopped, about 10 seconds. Add remaining ingredients in order listed, and blend on **Stir** until combined, about 15-20 seconds. **Turn blender OFF.** Store in refrigerator in an airtight container for up to 3 weeks.

Nutritional analysis per tablespoon (15 ml):

Calories 126 (100% from fat) • carbo. 0g • prot. 0g  
fat 14g • sat. fat 2g • chol. 0mg • sod. 56mg

### **BABY FOOD**

#### **PURÉED SQUASH**

Makes four 2-ounce (60 ml) servings

- 1 medium acorn squash  
(about 1-1/4 pounds/560 g)
- 1/4 cup (50 ml) orange juice or water

Cut squash in half, and remove seeds. Place in a microwave-safe dish with 2 tablespoons (25 ml) of water, cover with plastic wrap, and cook at 100% power until soft, about 12-14 minutes. Allow to cool, and scrape out pulp with a spoon. (There will be about 1-1/2 cups/375 ml pulp.) Place orange juice and pulp in blender jar in order listed. Place cover on blender jar. Turn blender ON and blend on **Purée** until smooth, about 30-40 seconds. **Turn blender OFF.** Scrape blender jar with a spatula. Turn blender ON and blend on **Purée** for 10-15 more seconds. **Turn blender OFF.** Store in an airtight container in the refrigerator for up to 1 week, or freeze in individual portions for up to 2 months.

Nutritional analysis per serving:

Calories 68 (0% from fat) • carbo. 16g • prot. 1g • fat 0g  
sat. fat 0g • chol. 0mg • sod. 4mg

#### **OATMEAL WITH BANANAS**

Makes six 2-ounce (60 ml) servings

- 1-1/2 cups (375 ml) milk

- 1/2 cup (125 ml) plus 2 tablespoons (25 ml) quick cooking oats
- 1/2 cup (125 ml) banana pieces,  
in 1" pieces (2.5 cm) (about 1/2 of a small banana)

Place milk in a small saucepan over medium heat and warm for about 5 minutes (do not boil). Add oats, and stir to combine. Reduce heat to low, and cook, stirring frequently, until oatmeal thickens, about 1 minute.

Place oatmeal mixture and banana in blender jar. Place cover on blender jar. Turn blender ON and blend on **Purée** until smooth, about 10-15 seconds. **Turn blender OFF.** Store in an airtight container in the refrigerator for 1-2 days. Add 1-2 tablespoons of milk if the oatmeal thickens too much during storage. Warm before serving.

Nutritional analysis per serving:

Calories 82 (20% from fat) • carbo. 13g • prot. 4g • fat 2g  
sat. fat 1g • chol. 5mg • sod. 31mg

---

#### **Variation:**

Substitute other ripe fruits such as peaches, pears, or fresh apricots.

---

#### **PURÉED PEACHES**

Makes four 2-ounce (50 ml) servings

- 4 medium peaches (about 6 ounces 180 g each), peeled, pits removed, cut into 1" (2.5 cm) pieces
- 1/2 cup (125 ml) orange juice or water

Place peaches in a steamer basket in a medium saucepan. Add enough water to be 1" (2.5 cm) deep in pan. Cover tightly, and bring to a boil over medium-high heat. Steam until peaches are soft, but not mushy, about 4-5 minutes. Replenish water if necessary during steaming.

Place orange juice and steamed peaches in blender jar in order listed. Place cover on blender jar. Turn blender ON and blend on **Purée** until smooth, about 25-30 seconds.

**Turn blender OFF.** Scrape blender jar with a spatula. Turn blender ON and blend on **Purée** for an additional 10-15 seconds. **Turn blender OFF.** Store in an airtight container in the refrigerator, for up to 1 week.

Nutritional analysis per serving:

Calories 84 (0% from fat) • carbo. 20g • prot. 1g • fat 0g  
sat. fat 0g • chol. 0mg • sod. 0mg

### CHICKEN WITH NOODLES

Makes twenty 2-ounce (60 ml) servings

1/2 pound (250 g) boneless, skinless chicken breast, cut into 1" (2.5 cm) pieces

1-1/2 cups (375 ml) reduced-sodium chicken broth

1/2 cup (125 ml) egg pastina

1/2 cup (125 ml) frozen peas

Place chicken, broth, pastina and peas in a medium saucepan. Cover; bring to a boil over medium-high heat. Reduce heat to low, and simmer, partially covered, until chicken is cooked and pastina is soft but not mushy, about 8-9 minutes. Remove from heat, and cool for 5 minutes.

Place chicken mixture in blender jar. Place cover on blender jar. Turn blender ON and blend on **Purée** until smooth, about 30 seconds. **Turn blender OFF.** Scrape blender jar with a spatula. Turn blender ON and continue blending on **Purée** for 30 more seconds. **Turn blender OFF.** Store in an airtight container in the refrigerator for up to 1 week, or freeze in individual portions for up to 2 months.

**Note: For a thinner consistency, add 1-2 tablespoons (15-25 ml) of milk.**

Nutritional analysis per serving:

Calories 24 (0% from fat) • carbo. 3g • prot. 3g • fat 0g  
sat. fat 0g • chol. 7mg • sod. 17mg

## BATTERS

### BUTTERMILK PANCAKES

Makes sixteen 4-inch (10 cm) pancakes

1-1/2 cups (375 ml) buttermilk

2 large eggs

1-1/4 cups (300 ml) all-purpose flour

3 tablespoons (45 ml) vegetable oil

1 tablespoon (15 ml) sugar

1 teaspoon (5 ml) baking soda

1/2 teaspoon (2 ml) baking powder

1/2 teaspoon (2 ml) salt

vegetable oil cooking spray

Place first eight ingredients, in order listed, in blender jar (not vegetable oil cooking spray). Place cover on blender jar. Turn blender ON and blend on **Purée** for 10 seconds. **Turn blender OFF.** Scrape blender jar with a spatula. Turn blender ON and blend on **Purée** for an additional 15-20 seconds. **Turn blender OFF.**

Coat a large non-stick skillet or griddle with vegetable oil cooking spray, and heat over medium heat. Pour batter into 4-inch pancakes. When they start to bubble, turn and brown the other side, about 45 seconds. Repeat with remaining batter, coating skillet with vegetable oil cooking spray as necessary.

Nutritional analysis per pancake:

Calories 75 (36% from fat) • carbo. 9g • prot. 3g • fat 3g  
sat. fat 1g • chol. 27mg • sod. 168mg

### CUISINART CRÊPES

Makes sixteen crêpes  
(about 8-9"/20-30 cm diameter)

1-2/3 cups (400 ml) warm water

3 tablespoons (45 ml) softened butter, in 1" pieces (2.5 cm)

1 cup (250 ml) all-purpose flour

3 large eggs

1 teaspoon (5 ml) vanilla extract

1/2 teaspoon (2 ml) salt

vegetable oil cooking spray

Place first six ingredients, in order listed, into blender jar (not vegetable oil cooking spray). Place cover on blender jar. Turn blender ON and blend on **Mix** for 10 seconds. **Turn blender OFF.** Scrape blender jar with a spatula. Turn blender ON and continue blending on **Mix** until smooth, about 15-20 seconds. **Turn blender OFF.**

Refrigerate in a covered container for 2 hours before using. Store in an airtight container in the refrigerator for up to 2 days. Stir well before using.

Coat a 9-1/2" (2.4 cm) non-stick skillet with vegetable oil cooking spray, and place over medium heat. Pour 3 tablespoons (45 ml) batter into skillet, and swirl to coat bottom of the pan evenly with a thin film. Cook about 1 minute on each side, or until lightly browned.

Reserve crêpes. Repeat with remaining batter, coating pan with vegetable oil cooking spray as necessary.

Serve with creamed chicken, fresh berries or sautéed apples.

Nutritional analysis per crêpe:

Calories 59 (46% from fat) • carbo. 6g • prot. 2g • fat 3g  
sat. fat 2g • chol. 46mg • sod. 107mg

### HONEY WHEAT WAFFLES

Makes six waffles (about 3 cups/750 ml batter)

1-1/2 cups (375 ml) milk

2 large eggs

3/4 cup (175 ml) plus 2 tablespoons (25 ml) all-purpose flour

1/2 cup (125 ml) whole wheat flour

4 tablespoons (50 ml) butter, melted

2 tablespoons (25 ml) honey

1 teaspoon (5 ml) baking powder

1 teaspoon (5 ml) vanilla extract

1/2 teaspoon (2 ml) salt

1/4 teaspoon (1 ml) baking soda

Preheat waffle iron. Place ingredients in blender jar in order listed. Place cover on blender jar.

Turn blender ON and blend on **Purée** for 10 seconds. **Turn blender OFF.** Scrape blender jar with spatula. Turn blender ON and continue blending on **Purée** until smooth, about 10-15 seconds.

**Turn blender OFF.**

Follow manufacturer's instructions to bake waffles.

Nutritional analysis per waffle:

Calories 239 (41% from fat) • carbo. 28g • prot. 7g  
fat 11g • sat. fat 6g • chol. 96mg • sod. 419mg

## SOUPS

### COLD GAZPACHO

Makes five 6-ounce (175 ml) servings

2 cups (500 ml) tomato juice, divided

1 rib celery, peeled, cut into 1" (2.5 cm) pieces

1 medium cucumber, peeled, cut in half lengthwise, seeds removed, in 1" (2.5 cm) pieces

1 clove garlic, peeled, cut in 4 pieces

1/2 medium green bell pepper, cored, seeded, cut into 1" (2.5 cm) pieces

1 small jalapeño pepper, cut in half, seeds removed, cut into 1/4" (6 mm) pieces

4 scallions, cut into 1" (2.5 cm) pieces

2 medium tomatoes, seeds removed, each cut into 8 pieces

2 tablespoons (25 ml) lemon juice

1/4 teaspoon (1 ml) black pepper

Place 1 cup tomato juice in blender jar. Add celery and next six ingredients. Place cover on blender jar. Turn blender ON and blend on **Purée** until vegetables are medium-finely chopped, about 10-15 seconds. **Turn blender OFF.** Place in a large serving bowl, and add remaining 1 cup tomato juice, lemon

juice, and pepper; stir to combine. Chill before serving.

Nutritional analysis per serving:

Calories 85 (11% from fat) • carbo. 16g • prot. 3g • fat 1g  
sat. fat 0g • chol. 0mg • sod. 511mg

### CREAM OF ASPARAGUS SOUP

Makes eight 6-ounce (175 ml) servings

3/4 cup (175 ml) parsley leaves

3 tablespoons (45 ml) butter or margarine

1 small onion, cut into 1" (2.5 cm) pieces

3/4 pound (340 g) asparagus, trimmed, cut into 1" (2.5 cm) pieces

3 cups (750 ml) chicken stock or broth

1 cup (250 ml) half-and-half

3 teaspoons (15 ml) cornstarch

1-1/2 cups (375 ml) cold water

salt and white pepper to taste

Place parsley in the blender jar. Place cover on blender jar. Turn blender ON and pulse on **Purée** until coarsely chopped, about 4-5 times. Reserve.

Melt butter in a medium saucepan over medium heat. Add onion, and cook until soft but not brown, about 2-3 minutes. Add asparagus, stock, and all but 1 tablespoon of reserved parsley. Cover; bring to a boil over medium-high heat. Reduce heat to low and cook, partially covered, until asparagus is tender, about 10-12 minutes.

Drain vegetables, being sure to reserve the cooking liquid. Allow cooking liquid to cool 5 minutes. Add 1 cup (250 ml) of the cooking liquid and half of the solids, in order listed, to the blender jar. Place cover on blender jar. Turn blender ON and blend on **Liquefy** until smooth, about 25-30 seconds. **Turn blender OFF.** Return the puréed vegetable mixture to the saucepan. Repeat with remaining 1 cup (250 ml) liquid and vegetables. Add remaining cooking liquid and half-and-half to puréed vegetables in the saucepan; stir to combine. Stir cornstarch into water,

and add to soup. Cook, stirring often, over medium heat, until soup thickens, about 6-8 minutes. Do not boil. Adjust seasonings to taste; garnish with remaining parsley, and serve.

Nutritional analysis per serving:

Calories 112 (64% from fat) • carbo. 7g • prot. 3g • fat 8g  
sat. fat 5g • chol. 23mg • sod. 610mg

### POTATO-LEEK SOUP

Makes four 6-ounce (175 ml) servings

1 tablespoon (15 ml) margarine

2 medium leeks, whites only, sliced horizontally and cut into 1" (2.5 cm) pieces

1 small onion, in 1" (2.5 cm) pieces

2 medium potatoes, peeled, in 1" (2.5 cm) pieces

1-3/4 cups (450 ml) reduced-sodium chicken broth

1/2 cup (125 ml) water

1/2 teaspoon (2 ml) salt

1/4 teaspoon (1 ml) white pepper

3 tablespoons (45 ml) chopped chives (optional)

Melt margarine in a medium saucepan over medium heat. Add leeks and onion; sauté until soft but not brown, about 5-8 minutes; stir occasionally. Add potatoes, broth, and water; cover; bring to a boil over medium-high heat. Reduce heat to low, and simmer, uncovered, until potatoes are soft, about 10-15 minutes.

Drain vegetables, being sure to reserve the cooking liquid. Allow cooking liquid to cool 5 minutes. Add half of the cooking liquid and half of the solids to the blender jar. Place cover on blender jar. Turn blender ON and blend on **Liquefy** until smooth, about 15-20 seconds. **Turn blender OFF.** Return the puréed vegetable mixture to the saucepan. Repeat with remaining liquid and vegetables and return vegetable mixture to saucepan. Add salt and pepper; stir to combine. Garnish with chopped chives, if desired.

Nutritional analysis per serving:

Calories 208 (17% from fat) • carbo. 38g • prot. 5g • fat 4g  
sat. fat 1g • chol. 0mg • sod. 380mg

## CREAMY CANTALOUPE SOUP

Makes five 6-ounce (175 ml) servings

- 1/2 cup (125 ml) orange juice
- 1 medium cantaloupe, seeds and peel removed, cut into 1" (2.5 cm) pieces
- 1 cup (250 ml) plain non-fat yogurt
- 2 tablespoons (25 ml) sugar\*
- 2 tablespoons (25 ml) port wine (optional)
- 2 tablespoons (25 ml) fresh mint leaves

Place orange juice and cantaloupe in blender jar. Place cover on blender jar. Turn blender ON and blend on **Purée** until smooth, about 20-25 seconds. Add yogurt, sugar, and wine (if using). Blend on **Purée** until smooth, about 15 seconds. **Turn blender OFF**. Serve chilled. Garnish with mint leaves.

\*Use less sugar if the cantaloupe is naturally sweet.

Nutritional analysis per serving:

Calories 96 (0% from fat) • carbo. 20g • prot. 4g • fat 0g  
sat. fat 0g • chol. 1mg • sod. 45mg

## CORN CHOWDER

Makes seven 6-ounce (175 ml) servings

- 1 tablespoon (15 ml) butter or margarine
- 1 medium leek, white only, washed, cut into 1" (2.5 cm) pieces
- 1 medium onion, cut into 1/4" (6 mm) pieces
- 2 celery ribs, peeled, sliced in 1/4" (6 mm) pieces
- 1 medium potato (about 9 ounces/255 g), peeled, cut into 1/2" (1.3 cm) pieces
- 1-2/3 cups (400 ml) reduced-sodium chicken broth
- 1 bay leaf
- 1/4 teaspoon (1 ml) dried thyme

1-1/3 cups (325 ml) 2% milk

- 2 cups (500 ml) corn kernels (fresh or frozen; thaw if frozen), divided salt and pepper to taste

Melt butter in a medium saucepan over medium heat. Add leek and onion; cook over medium heat for 3 minutes. Add celery, and sauté until soft, about 2 minutes. Add potato, broth, bay leaf, and thyme. Cover; bring to a boil over medium-high heat. Reduce heat to low, and cook, partially covered, until potato is tender, about 8-10 minutes.

Place milk and 1 cup corn kernels in blender jar. Place cover on blender jar. Turn blender ON and blend on **Liquefy** until well combined, about 25-30 seconds. **Turn blender OFF**. Add milk mixture and remaining corn to saucepan. Season with salt and pepper, if desired. Cook gently over low heat until heated through. Remove bay leaf before serving.

Nutritional analysis per serving:

Calories 208 (17% from fat) • carbo. 36g • prot. 7g • fat 4g  
sat. fat 2g • chol. 8mg • sod. 290mg

## DESSERTS

### ESPRESSO GRANITA

Makes six 1/2 cup (125 ml) servings

- 2 cups (500 ml) hot espresso coffee
- 1/2 cup (125 ml) sugar
- 1 cup (250 ml) chilled coffee

Combine espresso and sugar in a small bowl until sugar dissolves. Pour into ice cube trays, and freeze until solid, about 8 hours. Place chilled coffee and espresso cubes in blender jar. Place cover on blender jar. Turn blender ON and blend on **Liquefy** until thick, about 20-30 seconds. **Turn blender OFF**. Serve immediately in well-chilled parfait cups. Top with a dollop of whipped cream.

Nutritional analysis per serving:

Calories 68 (0% from fat) • carbo. 17g • prot. 0g • fat 0g  
sat. fat 0g • chol. 0mg • sod. 1mg

### FRESH LEMON GRANITA

Makes eight 1/2 cup (125 ml) servings

- 2 cups (500 ml) sugar
- 2 cups (500 ml) water
- 1-1/2 cups (375 ml) fresh lemon juice (juice of about 6 lemons)
- 1 tablespoon (15 ml) grated lemon zest\*

Combine sugar and water in a medium saucepan, and bring to a boil over medium-high heat. Reduce heat to low, and simmer until sugar dissolves, about 3-4 minutes. Cool completely\*\*. When cool, add lemon juice and zest; stir to combine. Pour into ice cube trays, and freeze until solid, about 8 hours. Place 12 frozen cubes in blender jar. Place cover on blender jar. Turn blender ON and press **Ice Crush** button 11-12 times or until ice is the consistency of snow. Continue crushing 12 cubes at a time until all are crushed. **Turn blender OFF**. Spoon into well-chilled parfait cups and serve immediately.

\* Zest is the colored part of the citrus rind. Do not use the white pith. For best results, remove zest from the lemon with a vegetable peeler.

\*\* Place mixture in a covered container, and store in the refrigerator overnight or chill, over an ice bath for 30 minutes.

Nutritional information per serving:

Calories 216 (0% from fat) • carbo. 54g • prot. 0g • fat 0g  
sat. fat 0g • chol. 0mg • sod. 1mg

### LEMON RICOTTA CHEESECAKE WITH RASPBERRY SAUCE

Makes eight servings (one 9"/23 cm cheesecake)

- 3 whole graham crackers
- 1 tablespoon (15 ml) cold butter, in 8 pieces
- 1 tablespoon (15 ml) sugar
- 4 strips lemon zest
- 1/2 cup (125 ml) liquid egg substitute
- 6 tablespoons (90 ml) lemon juice
- 30 ounces (850 g) part-skim ricotta cheese

1/2 cup (125 ml) sugar

Preheat oven to 325°F (160°C). Cover the outside of 9" springform pan with foil.

Break each graham cracker into 8 pieces and add to blender jar. Place cover on blender jar. Turn blender ON and blend on Mix until crushed, about 10-15 seconds. Add butter and 1 tablespoon (15 ml) sugar; blend on Mix until combined, about 10-15 seconds.

**Turn blender OFF.** Press mixture into bottom of pan, and bake 10 minutes.

Add lemon zest to clean and dry blender jar. Place cover on blender jar. Turn blender ON and pulse on **Purée** 5 times. **Turn blender OFF.** Scrape blender jar with a spatula. Turn blender ON. Blend on **Purée** for 15-20 seconds. Add egg substitute and remaining ingredients in the order listed; blend on **Liquefy** for 30-40 seconds. (It may look as if the ingredients are not mixing; however, the blender is working. After about 30 seconds, the mixture will start to circulate in the blender jar.) **Turn blender OFF.** Scrape the inside of the jar with a spatula. Turn blender ON and blend 15-20 more seconds until combined. **Turn blender OFF.** Pour into pre-baked crust, and bake until firm, about 1 hour. Cool completely on a wire rack, and then refrigerate at least 6 hours before serving. Serve with raspberry sauce (see page 11).

Nutritional analysis per serving (cheesecake only):

Calories 251 (39% from fat) • carbo. 24g • prot. 14g  
fat 11g • sat. fat 6g • chol. 37mg • sod. 211mg

## WHIPPED CREAM

See Recipe Tips section, page 7.

## BAKED ALMOND CUSTARD

Makes six servings

- 3 large eggs
- 1-1/2 cups (375 ml) 2% milk
- 1 cup (250 ml) evaporated skim milk
- 1/2 cup (125 ml) sugar
- 1 teaspoon (5 ml) almond extract
- 6 teaspoons (30 ml) finely chopped or slivered almonds

Preheat oven to 325°F (160°C). Add first five ingredients to blender jar (not almonds). Place cover on blender jar. Turn blender ON and blend on Mix until combined, about 10 seconds. **Turn blender OFF.** Divide mixture among six 6-ounce (175 ml) ramekins or custard cups, filling each about 3/4 full. Top each with 1 teaspoon almonds. Place ramekins in a 9" x 13" (23 x 33 cm) baking dish, and add hot water to reach 1" (2.5 cm) up the sides of the ramekins. Bake until a knife inserted in the center comes out clean, about 1 hour. Remove ramekins from water bath, and cool on a wire rack. Cover and chill in the refrigerator before serving.

Nutritional analysis per serving:

Calories 181 (25% from fat) • carbo. 25g • prot. 9g • fat 5g  
sat. fat 2g • chol. 112mg • sod. 111mg

# WARRANTY

## THREE-YEAR LIMITED WARRANTY

This warranty supersedes all previous warranties on this Cuisinart® product. This warranty is available to consumers only. You are a consumer if you own a Cuisinart® product that was purchased at retail for personal, family or household use. This warranty is not available to retailers or other commercial purchasers or owners.

We warrant that this Cuisinart® product will be free of defects in material or workmanship under normal home use for three years from the date of original purchase.

For warranty purposes, we would like to suggest that you register your product on-line at [www.cuisinart.ca](http://www.cuisinart.ca) to facilitate verification of the date of original purchase. However, should you not wish to register on-line we recommend the consumer to maintain original receipt indicating proof of purchase. In the event that you do not have proof of purchase date, the purchase date for purposes of this warranty will be the date of manufacture.

When calling our Authorized Service Centre for in warranty service please make reference to your model number and the manufacturing date code. This information can be found in the rating area on the body or underneath the base of your unit. The model number will follow the word Model: SPB-7C. The manufacturing date code is a 4 or 5 digit number. Example, 70630 would designate year, month & day (2007, June 30th).

If your Cuisinart® product should prove to be defective within the warranty period, we will repair it or, if we think it necessary, replace it. To obtain warranty service, please call our Consumer Service Centre toll-free at 1-800-472-7606 or write to:

Cuisinart Canada  
100 Conair Parkway,  
Woodbridge, Ontario L4H 0L2

To facilitate the speed and accuracy of your return, please also enclose \$10.00 for shipping and handling of the product. Please also be sure to include a return address, description of the product defect, product serial number, and any other information pertinent to the product's return. Please pay by cheque or money order.

**NOTE:** For added protection and secure handling of any Cuisinart® product that is being returned, we recommend you use a traceable, insured delivery service.

Cuisinart cannot be held responsible for in transit damage or for packages that are not delivered to us. Lost and/or damaged products are not covered under warranty.

Your Cuisinart® product has been manufactured to strict specifications and has been designed for use with Cuisinart® authorized accessories and replacement parts for your model.

These warranties expressly exclude any defects or damages caused by accessories, replacement parts or repair service other than those that have been authorized by Cuisinart. These warranties exclude all incidental or consequential damages.

## BEFORE RETURNING YOUR CUISINART PRODUCT

**Important:** If the nonconforming product is to be serviced by someone other than Cuisinart's Authorized Service Centre, please remind the servicer to call our Consumer Service Centre to ensure that the problem is properly diagnosed, the product serviced with the correct parts, and to ensure that the product is still under warranty.

©2007 Cuisinart  
Cuisinart® is a registered trademark of Cuisinart  
Cuisinart Canada  
100 Conair Parkway,  
Woodbridge, Ontario  
L4H 0L2  
98CC13510  
Printed in China

E IB-2794-CAN-D-TK

**[www.cuisinart.ca](http://www.cuisinart.ca)**