

# Cuisinart®

## INSTRUCTION AND RECIPE BOOKLET



**Mix It In™ Soft Serve Ice Cream Maker**

**ICE-45C**

For your safety and continued enjoyment of this product, always read the instruction book carefully before using.

IB-6405-CAN

---

# IMPORTANT SAFEGUARDS

When using an electrical appliance, basic safety precautions should always be followed to reduce the risk of fire, electric shock, and/or injury, including the following:

1. **READ ALL INSTRUCTIONS BEFORE USING.**
2. To protect against risk of electric shock, do not place cord, plug, or base of appliance in water or any other liquid.
3. Close supervision is necessary when any appliance is used by or near children.
4. Always unplug appliance from outlet when not in use, before putting on or taking off parts, and before cleaning.
5. Avoid contact with moving parts. Keep hands, hair, clothing, as well as spatulas and other utensils away from appliance during operation to reduce the risk of injury and/or damage to the appliance.
6. Do not operate any appliance with a damaged cord or plug, or after the appliance malfunctions, or is dropped or damaged in any manner. Return the appliance to the nearest Cuisinart Repair Center for examination, repair, electrical or mechanical adjustment.
7. The use of attachments other than those made by Cuisinart may cause fire, electric shock or risk of injuries.
8. Do not use outdoors.
9. Do not let cord hang over edge of table or counter, or touch hot surfaces.
10. Keep hands and utensils out of freezer bowl while in use to reduce the risk of injury to persons or to the appliance itself. **DO NOT USE SHARP OBJECTS OR UTENSILS INSIDE THE FREEZER BOWL!** Sharp objects will scratch and damage the inside of the freezer bowl. A rubber spatula or wooden spoon may be used when the appliance is in the OFF position.

11. This appliance is for household use. Any servicing other than cleaning and user maintenance should be done only by authorized Cuisinart Repair Personnel.
12. Do not use the freezer bowl on flames, hot plates or stoves. Do not expose to heat source. Do not wash in dishwasher; doing so may cause risk of fire, electric shock or injury.

## SAVE THESE INSTRUCTIONS FOR HOUSEHOLD USE ONLY

### SPECIAL CORD SET INSTRUCTIONS

A short power supply cord is provided to reduce the risks resulting from becoming entangled in or tripping over a longer cord.

Longer extension cords are available and may be used if care is exercised in their use.

If a long extension cord is used, the marked electrical rating of the extension cord should be at least as great as the electrical rating of the appliance. The longer cord should be arranged so that it will not drape over the countertop or tabletop where it can be pulled on by children or animals, or tripped over.

### NOTICE

This appliance has a polarized plug (one blade is wider than the other). To reduce the risk of electric shock, this plug will fit in a polarized outlet only one way. If the plug does not fit fully in the outlet, reverse the plug. If it still does not fit, contact a qualified electrician. Do not attempt to defeat this safety feature.

---

## CAUTION

This appliance is for household use. Any servicing other than cleaning and user maintenance should be performed by an authorized service representative.

- Do not immerse base in water.
- To reduce the risk of fire or electric shock, do not disassemble the base. Note: the base does not contain any user-serviceable parts.
- Repairs should be made only by authorized personnel.
- Check voltage to be sure that the voltage indicated on the name plate agrees with your voltage.
- Never clean with scouring powders or hard implements.

## CONTENTS

Important Safeguards . . . . .	2
Before First Use . . . . .	3
Freezing Time and Bowl Preparation . . . . .	3
Diagram, Features and Benefits . . . . .	4
Assembly . . . . .	5
Making Soft Serve Ice Cream . . . . .	5
Recommended Mix-ins . . . . .	6
Safety Feature . . . . .	6
Cleaning and Storage Instructions . . . . .	6-7
Troubleshooting . . . . .	7
Recipes . . . . .	8
Warranty . . . . .	23

## INTRODUCTION

Get ready to enjoy professional-quality soft ice cream, yogurt, sorbet and sherbet right at home, with your new Cuisinart® Mix It In™ Soft Serve Ice Cream Maker. Not only can you make all of your favorites, but with three built-in condiment dispensers, you can make them extra delicious! With the pull of a tab, sprinkles, chips and other toppings mix right into your frozen dessert as you fill up cones

or bowls. Operation is fully automatic, so just pick a recipe from the ones we've included, put the ingredients in the bowl, and turn the dial!

## BEFORE USING FOR THE FIRST TIME

DO NOT immerse this product in water. Wipe it with a moist cloth. Wash the lid, freezer bowl, mixing arm, condiment containers, condiment chute and drip tray in warm soapy water to remove any dust or residue from the manufacturing and shipping process. DO NOT clean any of the parts with abrasive cleaners or hard implements. DO NOT immerse unit in water or put unit under running water. Clean with a damp cloth only.

## FREEZING TIME AND BOWL PREPARATION

The freezer bowl must be completely frozen before you begin your recipe. Before freezing, wash and dry the bowl. Wrap it in a plastic bag to prevent freezer burn. We recommend that you place the freezer bowl in the back of your freezer where it is coldest. **Be sure to place the freezer bowl on a flat surface in its upright position for even freezing.** The length of time needed to reach the frozen state depends on how cold your freezer is. For the most convenient frozen desserts, leave your freezer bowl in the freezer at all times. You can take it out any time for immediate use. In general, freezing time should be a minimum of 12 hours. To determine whether the bowl is completely frozen, shake it. If you do not hear liquid moving, the cooling liquid is frozen.

**Reminder:** Your freezer should be set to 0°F (-18°C) to ensure proper freezing of all foods.

# FEATURES AND BENEFITS

- 1. Easy-lock Lid with Window** – Lid is designed to remove and lock easily. An ingredient window allows you to pour ingredients directly through the top and watch the freezing process.
- 2. Mixing Arm (not shown)** – Mixes and aerates ingredients in freezer bowl to create smooth soft ice cream.
- 3. 1½-Quart (1.4 L) Freezer Bowl (not shown)** – Contains cooling liquid within a double-insulated wall to create fast and even freezing. Double wall keeps the bowl cool and at an even temperature.
- 4. Three Condiment Containers** – Dispense the mix-ins of your choice. The front condiment container with a curved edge dispenses small mix-ins such as sprinkles. Two rectangular condiment containers dispense larger mix-ins such as mini M&M<sup>®</sup>s or mini chocolate morsels.
- 5. Condiment Dispensing Levers** – Pull out one of three levers to add the mix-ins of your choice into your soft ice cream.
- 6. Condiment Chute** – Mix-ins are dispensed from the chute into your ice cream cone or bowl while you dispense ice cream. Removable for easy cleaning.
- 7. Dispensing Bracket with Handle** – Dispenses the soft ice cream when handle is pulled down. Removable for easy cleaning.
- 8. Base** – Contains heavy-duty motor strong enough to make and dispense ice cream.
- 9. ON/OFF Power Dial**
- 10. Cone Holder** – Conveniently holds a stack of extra ice cream cones. Can hold both flat and pointed-bottom cones.

- 11. Removable Drip Tray** – Can be removed for easy cleaning. Dot in center of tray indicates where to place the ice cream cone.
- 12. Mix-in Gauge** – Check the size of mix-ins by dropping them through. Mix-ins that do not fit through will clog the ice cream maker.
- 13. Rubber Feet** – Nonslip feet keep base stationary during use.

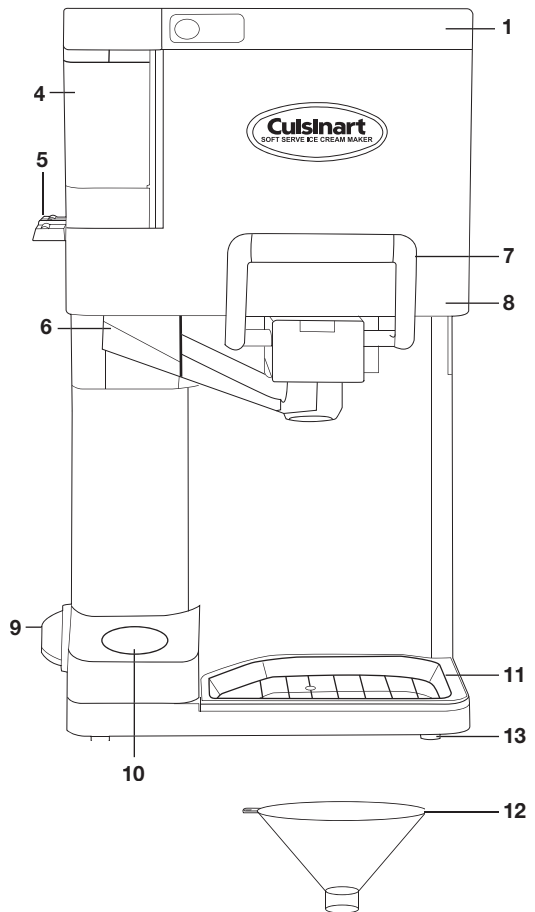

---

## ASSEMBLY

1. Insert the condiment containers into the indent on the top side of the ICE-45C so that they are firmly in place. The condiment container with the rounded edge should be inserted into the front space.
2. Place the small narrow cover over the condiment containers.
3. Attach the dispenser with handle by inserting the tab into the slot under the dispensing area, then push the dispenser upwards until it locks into place. (Make sure the handle is in the upright position.)

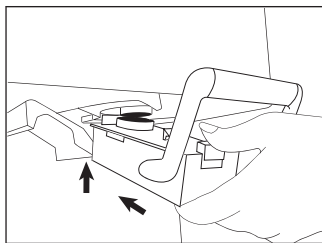

4. Slide the condiment chute into the space provided under the condiment containers. Be sure to slide it all the way in until it stops.

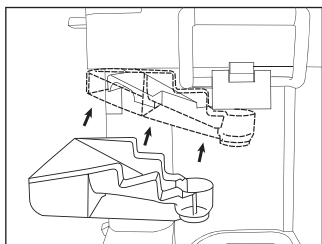

5. Place the drip tray on the base under the dispenser.
6. Push the mixing arm into the hole on the bottom of the lid.
7. Insert the freezer bowl. Make sure that it is securely in place.

8. Put the lid with mixing arm attached over the freezer bowl and push down until it clicks securely in place. To remove lid, push in and lift the two side tabs.

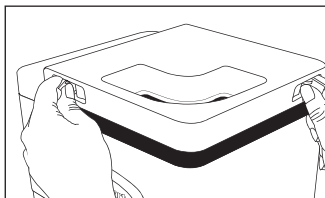

## MAKING SOFT SERVE ICE CREAM AND FROZEN DESSERTS

1. Fill the condiment containers with the desired mix-ins. Place small mix-ins such as sprinkles in the front condiment container with the curved edge. Place large mix-ins such as mini M&M<sup>®</sup>s or mini chocolate morsels in the rectangular condiment containers.

**NOTE: Do not place liquid condiments in the condiment containers.**

2. Use Cuisinart's recipes from the pages that follow. Do not fill the freezer bowl higher than  $\frac{1}{2}$ " (1.25 cm) from the top, as the ingredients will increase in volume during the freezing process. For best results, prepare ingredients in a container from which it is easy to pour.
3. Remove the freezer bowl from the freezer. (Remove plastic bag if you have wrapped freezer bowl.) Lift the lid and place freezer bowl inside the base.

**NOTE: Bowl will begin to defrost quickly once it has been removed from freezer. Use it immediately after removing from freezer.**

4. Push the mixing arm into the hole on the bottom of the lid.
5. Place lid with mixing arm on base and push down until it locks in place.

- 
6. Turn the power dial to the ON position. Mixing arm will begin to turn.
  7. Add ingredients to the freezer bowl by pouring them through the opening in the lid.
  8. Soft ice cream will be finished in as little as 20 minutes. The time will depend on the recipe and volume of the dessert you are making. If ingredients are refrigerated, ice cream making time will be reduced.
  9. Hold an ice cream cone or bowl one inch below the ice cream chute and pull down the handle to dispense the soft ice cream. Turn cup or bowl as you dispense to swirl ice cream.
  10. **Pull out** one, two or all three condiment dispensing levers to add the mix-ins of your choice into your soft ice cream or dessert. To stop the flow of mix-ins, push in the dispensing levers.
  11. When finished filling the cone or bowl, push the handle back up to stop the flow of ice cream.

**NOTES:** Some liquid may initially come out of the dispensing bracket when the handle is first pulled down. Use a cup to collect this liquid, then proceed with filling the first bowl or cone.

Do not store frozen desserts in the freezer bowl. Desserts will stick to the side of the freezer bowl and may damage the bowl. Store only in an airtight container.

The ice cream will lose its soft consistency and harden after it is stored in the freezer.

## RECOMMENDED MIX-INS

These items can be found in most well-stocked grocery stores and specialty grocery/gourmet food stores.

The location of the items will depend upon the individual store (for example, some items will be found near the ice cream and ice cream cones while others may be found in the baking section).

**Mini M&M®s\***

**Mini chocolate morsels\***

**Confetti sprinkles**

**Chocolate sprinkles**

**Caramel sprinkles**

**Praline crunch**

**Critter crunch or other decorative crunch bits**

**Almond brickle bits/chips**

**\*NOTE:** Do not use full sized M&M®s or chocolate morsels, they are too large to dispense. Use the mix-in gauge to make sure mix-ins are not too large. If they do not fit through the hole in the gauge, then they will clog the unit.

## SAFETY FEATURE

The Cuisinart® Mix It In™ Soft Serve Ice Cream Maker is equipped with a safety feature that automatically stops the unit if the motor overheats. This may occur if the dessert is extremely thick or if the unit has been running for an excessively long period of time, or if added condiments are too large. If ice cream is too thick to dispense, remove the bowl and eat the ice cream.

## DISASSEMBLING FOR CLEANING

1. Remove the lid and disconnect the mixing paddle.
2. Lift the freezer bowl up and out of the base.
3. Remove the condiment chute by pulling it toward you.
4. Remove the dispensing bracket with handle by pushing the button located on the centre of the face of the dispenser down and pulling it down and out towards you.

## TROUBLESHOOTING

Problem	Solution
<b>Ice cream is not ready in recommended time.</b>	Check recipe to make sure that the ingredients are correct. Keep the freezer bowl in the freezer for a longer amount of time before making ice cream. Do not let freezer bowl sit outside of the freezer for more than 5 minutes before making ice cream. Make sure your freezer is set to 0°F (-18°C).
<b>Ice cream is not dispensing.</b>	The ice cream may be too thick. Check the processing time. Check recipe to make sure that the ingredients are correct. Remove the bowl, scoop out and eat the ice cream.
<b>Motor stalls.</b>	The ice cream may be too thick. Check the processing time. Turn off ice cream maker. Clean ice cream maker and put freezer bowl in the freezer. Make a new batch once the bowl is frozen for the recommended amount of time.
<b>Mix-ins are not dispensing.</b>	Check the condiment chute to make sure that mix-ins are not stuck. Clean and dry the chute. Check mix-ins to make sure that they are not melting. Clean and dry condiment dispensers. Check for jammed mix-ins. Mix-ins may be too large.
<b>The mixing arm is not turning.</b>	Check to make sure there is no ice in the freezer bowl. Check to see if unit is on. The ice cream may be too thick.

## CLEANING

- 1. Unplug your Cuisinart® Mix It In™ Soft Serve Ice Cream Maker before cleaning.**
- 2. Base:** Wipe with a damp cloth and dry. Never use abrasives or immerse in water.
- 3. Freezer Bowl and Lid:** Wash by hand in warm soapy water and dry thoroughly. **DO NOT PUT IN THE DISHWASHER. DO NOT CLEAN WITH ABRASIVE CLEANSERS OR IMPLEMENTS.**
- 4. Handle with Dispensing Bracket:** Wash thoroughly by hand in warm soapy water. Be sure to eliminate all ice cream residue by cleaning the dispensing while it is opened (with the handle pushed down) and closed (with handle up).
- 5. Mixing Arm, Condiment Containers, Condiment Chute and Drip Tray:** Wash by hand in warm soapy water and dry thoroughly. These parts are also top rack dishwasher-safe. Be careful not to remove the small rubber pads that are located inside the condiment containers when cleaning. The rubber pads are a part of the condiment containers and are not removable.

## STORAGE

DO NOT put freezer bowl in freezer if bowl is wet. DO NOT store lid, mixing arm, base, drip tray or condiment containers in the freezer. You may store the freezer bowl in the freezer, in its upright position, for convenient, immediate use. Before freezing, wrap the bowl in a plastic bag to prevent freezer burn. Do not store frozen desserts in the freezer bowl. Transfer desserts to an airtight container for longer storage in the freezer.

When filled condiment containers are not in use, store in a cool, dark place. Empty containers if not used once a week. Start with fresh mix-ins so they don't spoil.

**NOTE:** The ice cream will lose its soft consistency and harden after it is stored in the freezer.

# RECIPES

## Quick & Easy Ice Cream

Simple Vanilla . . . . .	8
Simple Chocolate . . . . .	9
Strawberry . . . . .	9
Mint . . . . .	10
Coffee . . . . .	10
Cheesecake . . . . .	11
Peanut Butter . . . . .	11
Tropical Fruit . . . . .	12
Banana . . . . .	12
Coconut . . . . .	13
Pumpkin Sp'Ice . . . . .	13

### Frozen Yogurt

Vanilla . . . . .	14
Chocolate . . . . .	14
Mocha Latte . . . . .	15
Red Raspberry . . . . .	15
Strawberry Banana . . . . .	16
Cherry Vanilla . . . . .	16

### Sorbet & Sherbet

Blueberry . . . . .	17
Fresh Lemon . . . . .	17
Dark Chocolate . . . . .	18
Orange Creamsicle . . . . .	19
Peaches & Cream . . . . .	19
Piña Colada . . . . .	20
Root Beer Float . . . . .	20

### Dairy Free Frozen Dessert Treats

Banana Maple Tofu Frozen Dessert . . . . .	21
Chocolate Velvet Tofu Frozen Dessert . . . . .	21

# SIMPLE VANILLA ICE CREAM

Makes about ten ½-cup (125 ml) servings

- 1 cup (250 ml) whole milk, well chilled**
- ¾ cup (175 ml) granulated sugar**
- 2 cups (500 ml) heavy cream, well chilled**
- 1 to 2 teaspoons (5 to 10 ml) pure vanilla extract, to taste**

Place milk and sugar in a medium bowl. Use a hand mixer (about 1 to 2 minutes on low speed) or a whisk to mix until the sugar is dissolved. Stir in the heavy cream and vanilla to taste. If not making ice cream immediately, cover and refrigerate until ready to use.

Turn on ice cream maker and pour in ingredients. Allow to mix and freeze until desired serving consistency is reached. Begin checking consistency after 12 to 15 minutes of freezing. If ice cream is not thick enough, pour back into the freezer bowl and continue mixing/freezing until desired consistency is reached, checking every few minutes.

Serve in cups or cones, adding mix-ins while dispensing ice cream.

*Nutritional information per serving:*

*Calories 238 (68% from fat) • carb. 17g • pro. 2g  
• fat 19g • sat. fat 12g • chol. 69mg • sod. 30mg  
• calc. 60mg • fiber 0g*

### Lower Fat Variation:

- 1 cup (250 ml) reduced fat milk (2%)**
- ¾ cup (175 ml) granulated sugar**
- 2 cups (500 ml) half-and-half, well chilled**
- 1 to 2 teaspoons (5 to 10 ml) pure vanilla extract, to taste**

Mix and freeze as above.

*Nutritional information per serving:*

*Calories 132 (40% from fat) • carb. 18g • pro. 2g  
• fat 6g • sat. fat 4g • chol. 29mg • sod. 32mg  
• calc. 81mg • fiber 0g*

---

## SIMPLE CHOCOLATE ICE CREAM

Makes about ten ½-cup (125 ml) servings

- 2/3 cup (150 ml) unsweetened cocoa powder (Dutch process preferred)**
- 1/2 cup (125 ml) granulated sugar**
- 1/3 cup (75 ml) firmly packed brown sugar**
- 1 cup (250 ml) whole milk**
- 2 cups (500 ml) heavy cream**
- 1 teaspoon (5 ml) pure vanilla extract**

Place the cocoa and sugars in a medium bowl; stir with a whisk to combine and remove any lumps. Add the whole milk and use a hand mixer (about 1 to 2 minutes on low speed) or whisk to combine the milk with the cocoa powder and sugars until they are dissolved. Stir in the heavy cream and vanilla. If not freezing immediately, cover and refrigerate until ready to use.

Turn on ice cream maker and pour in ingredients. Allow to mix and freeze until desired serving consistency is reached. Begin checking consistency after 12 to 15 minutes of freezing. If ice cream is not thick enough, pour back into the freezer bowl and continue mixing/freezing until desired consistency is reached, checking every few minutes.

Serve in cups or cones, adding mix-ins while dispensing ice cream.

*Nutritional information per serving:*

*Calories 255 (62% from fat) • carb. 23g • pro. 3g  
• fat 18g • sat. fat 12g • chol. 69mg • sod. 33mg  
• calc. 75mg • fiber 3g*

## STRAWBERRY ICE CREAM

Makes about ten ½-cup (125 ml) servings

- 8 ounces (240 g) very red, ripe strawberries – fresh summer berries or frozen berries, thawed**
- 2/3 cup (150 ml) granulated sugar**
- 1/4 teaspoon (1 ml) pure vanilla extract**
- 2/3 cup (150 ml) whole milk**
- 1 1/3 cups (325 ml) heavy cream**

Place strawberries, granulated sugar, vanilla, and whole milk in a blender jar or food processor fitted with the metal “s” blade, and blend on high speed until completely smooth and homogenous, about 40 to 50 seconds. Pour into a bowl and stir in heavy cream. If not making ice cream immediately, cover and refrigerate until ready to use.

Turn on ice cream maker and pour in ingredients. Allow to mix and freeze until desired serving consistency is reached. Begin checking consistency after 12 to 15 minutes of freezing. If ice cream is not thick enough, pour back into the freezer bowl and continue mixing/freezing until desired consistency is reached, checking every few minutes.

Serve in cups or cones, adding mix-ins while dispensing ice cream.

*Nutritional information per serving:*

*Calories 178 (60% from fat) • carb. 17g • pro. 1g  
• fat 12g • sat. fat 8g • chol. 46mg • sod. 20mg  
• calc. 43mg • fiber 1g*

---

## MINT ICE CREAM

Makes about ten ½-cup (125 ml) servings

- 1 cup (250 ml) whole milk, well chilled
- ¾ cup (175 ml) granulated sugar
- 2 cups (500 ml) heavy cream, well chilled
- 1 teaspoon (5 ml) mint extract (may use peppermint or spearmint)
- 4-5 drops green or pink food colouring

Place milk and sugar in a medium bowl. Use a hand mixer (about 1 to 2 minutes on low speed) or a whisk to mix until the sugar is dissolved. Stir in the heavy cream and mint extract. Add food colouring in drops to reach desired color. If not freezing immediately, cover and refrigerate until ready to use.

Turn on ice cream maker and pour in ingredients. Allow to mix and freeze until desired serving consistency is reached. Begin checking consistency after 12 to 15 minutes of freezing. If ice cream is not thick enough, pour back into the freezer bowl and continue mixing/freezing until desired consistency is reached, checking every few minutes.

Serve in cups or cones, adding mix-ins while dispensing ice cream.

**For mint chip ice cream:** add mini chocolate morsels.

*Nutritional information per serving:*

Calories 238 (68% from fat) • carb. 17g • pro. 2g  
• fat 19g • sat. fat 12g • chol. 69mg • sod. 30mg  
• calc. 60mg • fiber 0g

## COFFEE ICE CREAM

Makes about ten ½-cup (125 ml) servings

- 1 cup (250 ml) whole milk, well chilled
- ½ cup (125 ml) granulated sugar
- ¼ cup (50 ml) packed brown sugar
- 1-1½ tablespoons (5 to 7 ml) instant espresso or coffee, to taste
- 2 cups (500 ml) heavy cream, well chilled
- 1 teaspoon (5 ml) pure vanilla extract

Place milk, both sugars, and espresso powder in a medium bowl. Use a hand mixer (about 1 to 2 minutes on low speed) or a whisk to mix until the sugar is dissolved, about 1 to 2 minutes on low speed. Stir in the heavy cream and vanilla to taste. If not making ice cream immediately, cover and refrigerate until ready to use.

Turn on ice cream maker and pour in ingredients. Allow to mix and freeze until desired serving consistency is reached. Begin checking consistency after 12 to 15 minutes of freezing. If ice cream is not thick enough, pour back into the freezer bowl and continue mixing/freezing until desired consistency is reached, checking every few minutes.

Serve in cups or cones, adding mix-ins while dispensing ice cream.

*Nutritional information per serving:*

Calories 257 (67% from fat) • carb. 19g • pro. 3g  
• fat 19g • sat. fat 12g • chol. 72mg • sod. 44mg  
• calc. 95mg • fiber 0g

---

## CHEESECAKE ICE CREAM

Makes about ten ½-cup (125 ml) servings

- 16 ounces (480 g) lowfat cream cheese, cut into 1-inch (2.5 cm) pieces, at room temperature**
- 1 can (14 ounces [420 ml]) fat free sweetened condensed milk**
- 1 cup (250 ml) fat free half-and-half**
- 1 teaspoon (5 ml) pure vanilla extract**
- ½ teaspoon (2 ml) pure lemon extract**
- ½ teaspoon (2 ml) pure almond extract**

Place cream cheese and sweetened condensed milk in a medium bowl. Use a hand mixer (about 1 to 2 minutes on low speed) or a whisk to mix until smooth. Stir in the half-and-half and extracts. If not freezing immediately, cover and refrigerate until ready to use.

Turn on ice cream maker and pour in ingredients. Allow to mix and freeze until desired serving consistency is reached. Begin checking consistency after 12 to 15 minutes of freezing. If ice cream is not thick enough, pour back into the freezer bowl and continue mixing/freezing until desired consistency is reached, checking every few minutes.

Serve in cups or cones, adding mix-ins while dispensing ice cream.

*Nutritional information per serving:*

*Calories 228 (33% from fat) • carb. 29g • pro. 8g  
• fat 8g • sat. fat 5g • chol. 19mg • sod. 317mg  
• calc. 189mg • fiber 0g*

---

## PEANUT BUTTER ICE CREAM

Creamy peanut butter ice cream is a favourite of kids of all ages.

Makes about ten ½-cup (125 ml) servings

- 1 cup (250 ml) creamy peanut butter**
- ⅔ cup (150 ml) granulated sugar**
- 1 cup (250 ml) whole milk**
- 1½ cups (375 ml) half-and-half**
- 1 teaspoon (5 ml) pure vanilla extract**

Place peanut butter and sugar in a medium bowl. Stir with a whisk until smooth. Add milk and stir until smooth and sugar is dissolved. Stir in half-and-half and vanilla. If not freezing immediately, cover and place in refrigerator until ready to use.

Turn on ice cream maker and pour in ingredients. Allow to mix and freeze until desired serving consistency is reached. Begin checking consistency after 12 to 15 minutes of freezing. If ice cream is not thick enough, pour back into the freezer bowl and continue mixing/freezing until desired consistency is reached, checking every few minutes.

Serve in cups or cones, adding mix-ins while dispensing ice cream.

*Nutritional information per serving:*

*Calories 265 (58% from fat) • carb. 21g • pro. 8g  
• fat 18g • sat. fat 6g • chol. 17mg • sod. 150mg  
• calc. 76mg • fiber 2g*

---

## TROPICAL FRUIT ICE CREAM

Citrus is blended with mango and papaya for a tropical flavour that everyone will love.

Makes about ten ½-cup (125 ml) servings

- ⅔ cup (150 ml) orange or tangerine juice concentrate, thawed**
- ⅔ cup (5 ounces [150 ml]) mango purée\***
- ⅔ cup (5 ounces [150 ml]) papaya purée\***
- ⅔ cup (150 ml) granulated sugar**
- ½ tablespoon (7 ml) fresh lemon juice**
- ½ teaspoon (2 ml) pure vanilla extract**
- ⅔ cup (150 ml) whole milk**
- ⅔ cup (150 ml) heavy cream**

Place the orange juice concentrate, mango purée, papaya purée, sugar, lemon juice, vanilla, and milk in a blender jar. Blend on high speed until smooth and homogenous, about 1 minute. Transfer to a bowl and stir in heavy cream. If not freezing immediately, cover and refrigerate until ready to use.

Turn on ice cream maker and pour in ingredients. Allow to mix and freeze until desired serving consistency is reached. Begin checking consistency after 12 to 15 minutes of freezing. If ice cream is not thick enough, pour back into the freezer bowl and continue mixing/freezing until desired consistency is reached, checking every few minutes.

Serve in cups or cones, adding mix-ins while dispensing ice cream.

\*Available in the frozen food section of well-stocked grocery stores. Fruit purées can also be made by puréeing fresh or frozen thawed fruit.

*Nutritional information per serving:*

*Calories 159 (35% from fat) • carb. 25g • pro. 1g  
• fat 6g • sat. fat 4g • chol. 24mg • sod. 17mg  
• calc. 39mg • fiber 1g*

## BANANA ICE CREAM

Makes about ten ½-cup (125 ml) servings

- 2 medium bananas, ripe but not overripe, cut into 1-inch pieces**
- ⅔ cup (150 ml) granulated sugar**
- 1 tablespoon (15 ml) fresh lemon juice**
- ¾ cup (175 ml) whole milk**
- ½ teaspoon (2 ml) pure vanilla extract**
- 1⅓ cups (325 ml) heavy cream**
- 1 to 2 drops yellow food colouring to give the yellow banana colour, optional**

Place the bananas, granulated sugar, lemon juice, whole milk, and vanilla in a blender jar and blend on high speed for 40 to 50 seconds until smooth, creamy and completely homogenous. Transfer to a bowl and stir in the heavy cream. Add yellow food colouring if using. If not freezing immediately, cover and refrigerate until ready to use.

Turn on ice cream maker and pour in ingredients. Allow to mix and freeze until desired serving consistency is reached. Begin checking consistency after 12 to 15 minutes of freezing. If ice cream is not thick enough, pour back into the freezer bowl and continue mixing/freezing until desired consistency is reached, checking every few minutes.

Serve in cups or cones, adding mix-ins while dispensing ice cream.

*Nutritional information per serving:*

*Calories 193 (56% from fat) • carb. 20g • pro. 1g  
• fat 12g • sat. fat 7g • chol. 46mg • sod. 21mg  
• calc. 44mg • fiber 0g*

**For Chocolate Banana Ice Cream:** Add ¼ cup (50 ml) unsweetened cocoa powder and ¼ cup (50 ml) chocolate syrup to the blender along with the first 5 ingredients and blend as directed.

---

## COCONUT ICE CREAM

Makes about ten ½-cup (125 ml) servings

- 2/3 cup (150 ml) sweetened coconut flakes**
- 2/3 cup (150 ml) granulated sugar**
- 1 cup (250 ml) lite coconut milk (do not use regular)**
- 1/2 teaspoon (2 ml) coconut extract**
- 1/2 teaspoon (2 ml) pure vanilla extract**
- 1 cup (250 ml) whole milk**
- 1 1/4 cups (300 ml) heavy cream**

Place the coconut flakes, granulated sugar, lite coconut milk, and both extracts in jar of a blender in that order. Blend on high speed until smooth and homogenous, about 40 to 50 seconds. Transfer to a bowl and stir in the milk and cream. If not making ice cream immediately, cover and refrigerate until ready to use.

Turn on ice cream maker and pour in ingredients. Allow to mix and freeze until desired serving consistency is reached. Begin checking consistency after 12 to 15 minutes of freezing. If ice cream is not thick enough, pour back into the freezer bowl and continue mixing/freezing until desired consistency is reached, checking every few minutes.

Serve in cups or cones, adding mix-ins while dispensing ice cream.

*Nutritional information per serving:*

*Calories 206 (62% from fat) • carb. 18g • pro. 2g  
• fat 15g • sat. fat 10g • chol. 44mg • sod. 37mg  
• calc. 49mg • fiber 0g*

## PUMPKIN SP'ICE CREAM

Makes about ten ½-cup (125 ml) servings

- 1 1/4 cups (300 ml) whole milk**
- 3/4 cup (175 ml) packed light or dark brown sugar**
- 1 1/2 tablespoons (25 ml) molasses or dark corn syrup**
- 1 1/3 cups (325 ml) pumpkin purée (solid pack pumpkin)**
- 1 teaspoon (5 ml) cinnamon**
- 3/4 teaspoon (3.75 ml) ginger**
- 1/8 teaspoon (0.5 ml) freshly ground nutmeg**
- 1 1/2 cups (375 ml) heavy cream**
- 1 teaspoon (5 ml) pure vanilla extract**

Place 1 cup (250 ml) of the milk in jar of a blender with the brown sugar, molasses, pumpkin purée, cinnamon, ginger, and nutmeg. Blend on high speed until smooth and homogenous, about 30 seconds. Transfer to a bowl and stir in the remaining cold milk and cream. If not making ice cream immediately, cover and refrigerate until ready to use.

Turn on ice cream maker and pour in ingredients. Allow to mix and freeze until desired serving consistency is reached. Begin checking consistency after 12 to 15 minutes of freezing. If ice cream is not thick enough, pour back into the freezer bowl and continue mixing/freezing until desired consistency is reached, checking every few minutes.

Serve in cups or cones, adding mix-ins while dispensing.

*Nutritional information per serving:*

*Calories 217 (58% from fat) • carb. 21g • pro. 2g • fat 14g  
• sat. fat 9g • chol. 53mg • sod. 35mg  
• calc. 85mg • fiber 1g*

---

## VANILLA FROZEN YOGURT

Makes about ten ½-cup (125 ml) servings

- 1 ⅓ cups (325 ml) whole milk**
- ⅔ cup (150 ml) granulated sugar**
- 2 ½ cups (625 ml) fat free or lowfat vanilla yogurt**
- 1 teaspoon (5 ml) pure vanilla extract**

Place whole milk and sugar in a medium bowl. Use a hand mixer (about 1 to 2 minutes on low speed) or a whisk to mix until sugar is dissolved. Stir in the yogurt and vanilla. If not freezing immediately, cover and refrigerate until ready to use.

Turn on ice cream maker and pour in ingredients. Allow to mix and freeze until desired serving consistency is reached. Begin checking consistency after 12 to 15 minutes of freezing. If frozen yogurt is not thick enough, pour back into the freezer bowl and continue mixing/freezing until desired consistency is reached, checking every few minutes.

Serve in cups or cones, adding mix-ins while dispensing frozen yogurt.

*Nutritional information per serving:*

*Calories 99 (10% from fat) • carb. 19g • pro. 4g  
• fat 1g • sat. fat 1g • chol. 6mg • sod. 54mg  
• calc. 126mg • fiber 0g*

## CHOCOLATE FROZEN YOGURT

Makes about ten ½-cup (125 ml) servings

- 1 cup (250 ml) whole milk, warmed to a simmer**
- 8 ounces (240 g) semisweet chocolate, chopped (may use semisweet chocolate morsels)**
- ¼ cup (50 ml) granulated sugar**
- 2 cups (500 ml) fat free or lowfat yogurt**
- 1 teaspoon (5 ml) pure vanilla extract**

Stir the chocolate and sugar into the warmed milk. Stir until chocolate is completely melted and sugar is dissolved. Let come to room temperature. Add the yogurt and vanilla and stir with a whisk until completely combined. If not freezing immediately, cover and refrigerate until ready to use.

Turn on ice cream maker and pour in ingredients. Allow to mix and freeze until desired serving consistency is reached. Begin checking consistency after 12 to 15 minutes of freezing. If frozen yogurt is not thick enough, pour back into the freezer bowl and continue mixing/freezing until desired consistency is reached, checking every few minutes.

Serve in cups or cones, adding mix-ins while dispensing frozen yogurt.

*Nutritional information per serving:*

*Calories 179 (44% from fat) • carb. 23g • pro. 5g  
• fat 10g • sat. fat 6g • chol. 4mg • sod. 41mg  
• calc. 121mg • fiber 1g*

---

## MOCHA LATTE FROZEN YOGURT

A frozen yogurt with coffeehouse flavours.

Makes about ten ½-cup (125 ml) servings

- ¾ cup (175 ml) whole milk**
- ⅓ cup (75 ml) packed brown sugar**
- 2 tablespoons (30 ml) granulated sugar**
- 1½-2 tablespoons (25 to 30 ml) unsweetened cocoa powder, to taste**
- 1½-2 tablespoons (25 to 30 ml) instant espresso powder, to taste**
- 2 cups (500 ml) fat free or lowfat vanilla yogurt**
- ⅓ cup (75 ml) half-and-half**
- 1 teaspoon (5 ml) pure vanilla extract**

Place milk, both sugars, cocoa powder, and espresso powder in a medium bowl. Use a hand mixer (about 1 to 2 minutes on low speed) or a whisk to mix until the sugar is dissolved. Stir in the yogurt, half-and-half, and vanilla until well blended. If not freezing immediately, cover and refrigerate until ready to use.

Turn on ice cream maker and pour in ingredients. Allow to mix and freeze until desired serving consistency is reached. Begin checking consistency after 12 to 15 minutes of freezing. If frozen yogurt is not thick enough, pour back into the freezer bowl and continue mixing/freezing until desired consistency is reached, checking every few minutes.

Serve in cups or cones, adding mix-ins while dispensing frozen yogurt.

*Nutritional information per serving:*

*Calories 99 (15% from fat) • carb. 18g • pro. 3g  
• fat 2g • sat. fat 1g • chol. 6mg • sod. 43mg  
• calc. 118mg • fiber 0g*

---

## RED RASPBERRY FROZEN YOGURT

Makes about ten ½-cup (125 ml) servings

- 12 ounces (360 g) fresh red raspberries (or frozen, thawed)**
- ¾ cup (175 ml) granulated sugar**
- ¼ cup (50 ml) fresh lime juice**
- ½ cup (125 ml) whole milk**
- 1⅓ cups (325 ml) fat free or lowfat vanilla yogurt**

Place the raspberries, sugar, and lime juice in a blender jar (or food processor fitted with the metal “s” blade) and blend on high until smooth and homogenous. If desired pour through a fine mesh sieve to strain out the seeds (press with the back of a wooden spoon or spatula). Transfer raspberry liquid to a medium bowl. Stir in milk and yogurt with a whisk. If not freezing immediately, cover and refrigerate until ready to use.

Turn on ice cream maker and pour in ingredients. Allow to mix and freeze until desired serving consistency is reached. Begin checking consistency after 12 to 15 minutes of freezing. If frozen yogurt is not thick enough, pour back into the freezer bowl and continue mixing/freezing until desired consistency is reached, checking every few minutes.

Serve in cups or cones, adding mix-ins while dispensing frozen yogurt.

*Nutritional information per serving:*

*Calories 113 (3% from fat) • carb. 26g • pro. 2g  
• fat 0g • sat. fat 0g • chol. 2g • sod. 27mg  
• calc. 75mg • fiber 1g*

---

## STRAWBERRY BANANA FROZEN YOGURT

Makes about ten ½-cup (125 ml) servings

- 1 large (about 6 ounces [170 g]) banana, peeled and cut into 1-inch (2.5 cm) pieces**
- 8 ounces (240 g) fresh (hulled) or frozen, thawed strawberries**
- ½ cup (125 ml) granulated sugar**
- ½ cup (125 ml) whole milk**
- ¼ cup (50 ml) orange juice concentrate, thawed**
- ½ teaspoon (2 ml) pure vanilla extract**
- 1½ cups (375 ml) fat free or lowfat vanilla yogurt**

Place the banana, strawberries, sugar, milk, orange juice concentrate, and vanilla in a blender jar (or food processor fitted with the metal “s” blade) and blend on high until smooth and homogenous. Transfer to a medium bowl and stir in yogurt with a whisk. If not freezing immediately, cover and refrigerate until ready to use.

Turn on ice cream maker and pour in ingredients. Allow to mix and freeze until desired serving consistency is reached. Begin checking consistency after 12 to 15 minutes of freezing. If frozen yogurt is not thick enough, pour back into the freezer bowl and continue mixing/freezing until desired consistency is reached, checking every few minutes.

Serve in cups or cones, adding mix-ins while dispensing frozen yogurt.

*Nutritional information per serving:*

*Calories 113 (7% from fat) • carb. 24g • pro. 4g  
• fat 1g • sat. fat 1g • chol. 4mg • sod. 33mg  
• calc. 89mg • fiber 1g*

## CHERRY VANILLA FROZEN YOGURT

Makes about ten ½-cup (125 ml) servings

- 12 ounces (360 g) pitted sweet cherries, fresh, canned and drained (measure after draining), or frozen, thawed**
- 1 cup (250 ml) whole milk**
- ¼ cup (50 ml) granulated sugar**
- 1 teaspoon (5 ml) pure vanilla extract**
- 1½ cups (375 ml) lowfat or fat free vanilla yogurt**

Place the cherries, whole milk, granulated sugar, and vanilla in a blender jar and blend on high speed for 40 to 50 seconds until smooth, creamy and completely homogenous. Transfer to a bowl and stir in the yogurt. If not freezing immediately, cover and refrigerate until ready to use.

Turn on ice cream maker and pour in ingredients. Allow to mix and freeze until desired serving consistency is reached. Begin checking consistency after 12 to 15 minutes of freezing. If frozen yogurt is not thick enough, pour back into the freezer bowl and continue mixing/freezing until desired consistency is reached, checking every few minutes.

Serve in cups or cones, adding mix-ins while dispensing frozen yogurt.

*Nutritional information per serving:*

*Calories 84 (10% from fat) • carb. 17g • pro. 3g  
• fat 1g • sat. fat 1g • chol. 4mg • sod. 34mg  
• calc. 95mg • fiber 1g*

---

## BLUEBERRY SORBET

Makes about ten ½-cup (125 ml) servings

- 1 ⅓ cups (325 ml) granulated sugar**
- ⅔ cup (150 ml) water**
- 2 pounds (1 kg) fresh or frozen blueberries (wild if possible)**
- 3 tablespoons (45 ml) fresh lime juice**
- 2 tablespoons (30 ml) light corn syrup**

Combine the sugar and water in a medium saucepan and bring to a boil over medium-high heat. Reduce heat to low and simmer without stirring until the sugar dissolves, about 3 to 5 minutes. Stir in blueberries and cook until they pop open. Allow to cool for 10 to 15 minutes. When cool, transfer the blueberry mixture to a blender and add the lemon juice; blend on high speed until smooth and homogenous; stir in corn syrup. Pour mixture through a fine mesh strainer to remove seeds. Cover and chill for at least 4 hours before freezing.

Turn on ice cream maker and pour in ingredients. Allow to mix and freeze until desired serving consistency is reached. Begin checking consistency after 12 to 15 minutes of freezing. If sorbet is not thick enough, pour back into the freezer bowl and continue mixing/freezing until desired consistency is reached, checking every few minutes.

Serve in cups, adding mix-ins while dispensing sorbet.

*Nutritional information per serving:*

*Calories 139 (2% from fat) • carb. 35g • pro. 0g  
• fat 0g • sat. fat 0g • chol. 0mg • sod. 4mg  
• calc. 6mg • fiber 1g*

## FRESH LEMON SORBET

Bits of fresh citrus zest add a burst of flavor to these refreshing sorbets.

Makes about eight ½-cup (125 ml) servings

- 2 cups (500 ml) sugar**
- 2 cups (500 ml) water**
- 1 ½ cups (375 ml) freshly squeezed lemon juice**
- 1 tablespoon (15 ml) finely chopped lemon zest\***

Combine the sugar and water in a medium saucepan and bring to a boil over medium-high heat. Reduce heat to low and simmer without stirring until the sugar dissolves, about 3 to 5 minutes. Cool completely. This is called a simple syrup, and may be made ahead in larger quantities to have on hand for making citrus sorbets. Allow to cool completely. When cool, add the lemon juice and zest; stir to combine. If not freezing immediately, cover and refrigerate until ready to use.

Turn on ice cream maker and pour in ingredients. Allow to mix and freeze until desired serving consistency is reached. Begin checking consistency after 12 to 15 minutes of freezing. If sorbet is not thick enough, pour back into the freezer bowl and continue mixing/freezing until desired consistency is reached, checking every few minutes.

Serve in cups, adding mix-ins while dispensing sorbet.

*Nutritional analysis per serving:*

*Calories 204 (0% from fat) • carb. 54g • pro. 0g  
• fat 0g • sat. fat 0g • chol. 0mg • sod. 3mg  
• calc. 5mg • fiber 0g*

**Fresh Lime Sorbet:** Substitute 1 ½ cups (375 ml) freshly squeezed lime juice for the lemon juice and 1 tablespoon (15 ml) finely chopped lime zest for the lemon zest.

---

**Fresh Lemon-Lime Sorbet:** Use half lemon juice and half lime juice and ½ tablespoon (7 ml) each of finely chopped lemon and lime zest.

**Fresh Pink Grapefruit Sorbet:** Substitute 1½ cups (375 ml) freshly squeezed pink grapefruit juice for the lemon juice, and 1 tablespoon (15 ml) finely chopped grapefruit zest for the lemon zest. Add ¼ cup (50 ml) orgeat syrup to the mixture (orgeat syrup is used for cocktails such as a mai tai or scorpion and can be found with the drink mixers in most grocery stores).

\*When zesting a lemon or lime use a vegetable peeler to remove the coloured part of the citrus rind.

## DARK CHOCOLATE SORBET

Makes about ten ½-cup (125 ml) servings

**2½ cups (625 ml) water**  
**1½ cups (375 ml) brown sugar, packed**  
**1½ cups (375 ml) unsweetened cocoa powder**  
**1 teaspoon (5 ml) cinnamon**  
**1 tablespoon (15 ml) pure vanilla extract**

Combine the water and sugar in a 3½ quart (3.3 L) saucepan and place over medium heat. Stir until the sugar dissolves. Whisk in the cocoa and cinnamon; bring mixture to a simmer. Simmer for 3 minutes, stirring constantly. Remove from heat and pour through a fine strainer into a bowl. Stir in the vanilla. Cover and chill in the refrigerator for 8 hours.

Stir the chilled mixture. Turn on ice cream maker and pour in ingredients. Allow to mix and freeze until desired serving consistency is reached. Begin checking consistency after 12 to 15 minutes of freezing. If sorbet is not thick enough, pour back into the freezer bowl and continue mixing/freezing until desired consistency is reached, checking every few minutes.

Serve in cups, adding mix-ins while dispensing sorbet.

*Nutritional information per serving:*

*Calories 151 (11% from fat) • carb. 37g • pro. 2g  
• fat 2g • sat. fat 1g • chol. 0mg • sod. 89mg  
• calc. 44mg • fiber 4g*

---

## ORANGE CREAMSICLE SHERBET

Makes about eight ½-cup (125 ml) servings

- 1¾ cups (a 12-ounce [425 ml] can) frozen orange juice concentrate, thawed**
- ¼ cup (50 ml) granulated sugar**
- 1½ cups (375 ml) whole milk**
- 2 teaspoons (10 ml) pure vanilla extract**
- ½ cup (125 ml) fat free or regular half-and-half**

Place the orange juice concentrate, sugar, milk, and vanilla in a blender jar (or food processor fitted with the metal “s” blade) and blend on high until smooth and homogenous. Transfer to a medium bowl and stir in half-and-half with a whisk. If not freezing immediately, cover and refrigerate until ready to use.

Turn on ice cream maker and pour in ingredients. Allow to mix and freeze until desired serving consistency is reached. Begin checking consistency after 12 to 15 minutes of freezing. If sherbet is not thick enough, pour back into the freezer bowl and continue mixing/freezing until desired consistency is reached, checking every few minutes.

Serve in cups or cones, adding mix-ins while dispensing sherbet.

*Nutritional information per serving:*

*Calories 142 (11% from fat) • carb. 29g • pro. 2g  
• fat 2g • sat. fat 1g • chol. 7mg • sod. 46mg  
• calc. 85mg • fiber 0g*

---

## PEACHES & CREAM SHERBET

Makes about eight ½-cup (125 ml) servings

- 1 pound (500 g) peach slices (fresh or frozen, thawed)**
- ⅔ cup (150 ml) granulated sugar**
- ½ cup (125 ml) peach nectar or juice**
- 1½ tablespoons (25 ml) fresh lemon juice**
- ¾ cup (175 ml) whole milk**
- ¾ cup (175 ml) fat free or regular half-and-half**
- ¼ teaspoon (1 ml) pure almond extract, optional**

Place the peaches, sugar, peach nectar, and lemon juice in a blender jar (or food processor fitted with the metal “s” blade) and blend on high until smooth and homogenous. Add milk and blend until homogenous. Add almond extract if using. Transfer to a bowl and stir in half-and-half. If not freezing immediately, cover and refrigerate until ready to use.

Turn on ice cream maker and pour in ingredients. Allow to mix and freeze until desired serving consistency is reached. Begin checking consistency after 12 to 15 minutes of freezing. If sherbet is not thick enough, pour back into the freezer bowl and continue mixing/freezing until desired consistency is reached, checking every few minutes.

Serve in cups or cones, adding mix-ins while dispensing frozen sherbet.

*Nutritional information per serving:*

*Calories 122 (8% from fat) • carb. 27g • pro. 2g  
• fat 1g • sat. fat 1g • chol. 4mg • sod. 51mg  
• calc. 50mg • fiber 1g*

---

## PIÑA COLADA SHERBET

Makes about ten ½-cup (125 ml) servings

- 1 20-ounce (600 ml) can pineapple tidbits or chunks, packed in juice, not drained**
- ⅓ cup (75 ml [medium pack]) sweetened coconut flakes**
- ⅔ cup (150 ml) granulated sugar**
- 1 tablespoon (15 ml) fresh lime juice**
- ¾ cup (175 ml) whole milk**
- 1 cup (250 ml) lite coconut milk**
- 1 teaspoon (5 ml) pure vanilla or rum extract**

Place the pineapple, coconut, sugar, coconut milk and lime juice in a blender jar (or food processor fitted with the metal “s” blade) and blend on high until smooth and homogenous. Stir in milk with a whisk. If not freezing immediately, cover and refrigerate until ready to use.

Turn on ice cream maker and pour in ingredients. Allow to mix and freeze until desired serving consistency is reached. Begin checking consistency after 12 to 15 minutes of freezing. If frozen yogurt is not thick enough, pour back into the freezer bowl and continue mixing/freezing until desired consistency is reached, checking every few minutes.

Serve in cups or cones, adding mix-ins while dispensing frozen yogurt.

*Nutritional information per serving:*

*Calories 157 (20% from fat) • carb. 31g • pro. 2g  
• fat 4g • sat. fat 3g • chol. 4mg • sod. 26mg  
• calc. 47mg • fiber 1g*

## ROOT BEER FLOAT SHERBET

Tastes just like the soda shop favorite.

Makes about ten ½-cup (1125 ml) servings

- 2 12-ounce (350 ml) bottles root beer, allowed to go flat or somewhat flat**
- ½ cup (125 ml) lowfat sweetened condensed milk**
- ½ cup (125 ml) lowfat or regular half-and-half**

Place all ingredients in a medium bowl and stir to blend. If not freezing immediately, cover and refrigerate until ready to use.

Turn on ice cream maker and pour in ingredients. Allow to mix and freeze until desired serving consistency is reached. Begin checking consistency after 12 to 15 minutes of freezing. If sherbet is not thick enough, pour back into the freezer bowl and continue mixing/freezing until desired consistency is reached, checking every few minutes.

Serve in cups or cones, adding mix-ins while dispensing sherbet.

*Nutritional information per serving:*

*Calories 86 (8% from fat) • carb. 18g • pro. 2g  
• fat 1g • sat. fat 1g • sod. 43mg  
• calc. 55mg • fiber 0g*

---

## BANANA MAPLE TOFU FROZEN DESSERT

Makes about eight ½-cup (125 ml) servings

- 1 cup (250 ml) vanilla soy milk (calcium-enriched suggested)
- ⅔ cup (150 ml) pure maple syrup
- 1 medium banana (about 6 ounces [180 g]), peeled, cut into 1-inch (2.5 cm) pieces
- 1½ teaspoons (25 ml) pure vanilla extract
- 1 pound (500 g) silken tofu, drained, cut into 2-inch (5 cm) pieces

Place all ingredients in a blender jar in the order listed. Blend on high speed until completely smooth and homogenous, about 40 to 50 seconds. If not making frozen dessert immediately, cover and refrigerate until ready to use.

Turn on ice cream maker and pour in ingredients. Allow to mix and freeze until desired serving consistency is reached. Begin checking consistency after 12 to 15 minutes of freezing. If frozen dessert is not thick enough, pour back into the freezer bowl and continue mixing/freezing until desired consistency is reached, checking every few minutes.

Serve in cups or cones, adding mix-ins while dispensing frozen dessert.

*Nutritional information per serving:*

Calories 171 (19% from fat) • carb. 29g • pro. 6g  
• fat 4g • sat. fat 0g • chol. 0mg • sod. 32mg  
• calc. 111mg • fiber 1g

## CHOCOLATE VELVET TOFU FROZEN DESSERT

A chocolaty treat for those who cannot have milk/dairy-based desserts.

Makes about eight ½-cup (125 ml) servings

- 1 cup (250 ml) vanilla soy milk (calcium - enriched suggested)
- ½ cup (125 ml) packed brown sugar
- ½ cup (125 ml) granulated sugar
- ½ cup (125 ml) unsweetened cocoa powder
- 1½ teaspoons (7 ml) pure vanilla extract
- 1 pound (500 g) silken tofu, drained, cut into 2-inch (5 cm) pieces

Place all ingredients in a blender jar in the order listed. Blend on high speed until completely smooth and homogenous, about 40 to 50 seconds. If not making frozen dessert immediately, cover and refrigerate.

Turn on ice cream maker and pour in ingredients. Allow to mix and freeze until desired serving consistency is reached. Begin checking consistency after 12 to 15 minutes of freezing. If frozen dessert is not thick enough, pour back into the freezer bowl and continue mixing/freezing until desired consistency is reached, checking every few minutes.

Serve in cups or cones, adding mix-ins while dispensing frozen dessert.

*Nutritional information per serving:*

Calories 185 (17% from fat) • carb. 33g • pro. 5g  
• fat 4g • sat. fat 0g • chol. 0mg • sod. 34mg  
• calc. 94mg • fiber 1g

---

# IMPORTANT

- Be sure to place the freezer bowl on a flat surface in its upright position for even freezing.
- Bowl will begin to defrost quickly once it has been removed from freezer. Use immediately after removing from freezer.
- Frozen desserts will be done in 20 to 30 minutes depending on the recipe and volume of dessert you are making.
- You must watch ice cream to determine when to dispense. If you wait too long, icecream may get too thick and you might not be able to dispense. If this happens, remove the bowl, scoop out and enjoy the icecream. This may occur if too much time elapses in between dispensing cones.
- Some liquid may come out of the dispensing bracket when the handle is first pulled down. Use a cup to collect the liquid, and then proceed with filling the first bowl or cone.
- Do not place liquid condiments in the condiment containers.
- Dry the condiment containers and condiment chute thoroughly after washing so that condiments do not get damp.

---

## LIMITED THREE-YEAR WARRANTY

This warranty supersedes all previous warranties on this Cuisinart® product. This warranty is available to consumers only. You are a consumer if you own a Cuisinart® product that was purchased at retail for personal, family or household use. This warranty is not available to retailers or other commercial purchasers or owners.

We warrant that this Cuisinart® product will be free of defects in material or workmanship under normal home use for three years from the date of original purchase.

For warranty purposes, we would like to suggest that you register your product on-line at [www.cuisinart.ca](http://www.cuisinart.ca) to facilitate verification of the date of original purchase. However, should you not wish to register on-line we recommend the consumer to maintain original receipt indicating proof of purchase. In the event that you do not have proof of purchase date, the purchase date for purposes of this warranty will be the date of manufacture.

When calling our Authorized Service Centre for in warranty service please make reference to your model number and the manufacturing date code. This information can be found in the rating area on the body or underneath the base of your unit. The model number will follow the word Model: ICE45C. The manufacturing date code is a 4 or 5 digit number. Example, 60630 would designate year, month & day (2006, June 30th).

If your Cuisinart® product should prove to be defective within the warranty period, we will repair it or, if we think it necessary, replace it. To obtain warranty service, please call our Consumer Service Centre toll-free at 1-800-472-7606 or write to:

Cuisinart Canada  
156 Parkshore Drive  
Brampton, Ont. L6T 5M1

To facilitate the speed and accuracy of your return, please also enclose \$10.00 for shipping and handling of the product. Please also be sure to include a return address, description of the product defect, product serial number, and any other information pertinent to the product's return. Please pay by cheque or money order.

**NOTE:** For added protection and secure handling of any Cuisinart® product that is being returned, we recommend you use a traceable, insured delivery service.

Cuisinart cannot be held responsible for in transit damage or for packages that are not delivered to us. Lost and/or damaged products are not covered under warranty.

Your Cuisinart® product has been manufactured to strict specifications and has been designed for use with Cuisinart® authorized accessories and replacement parts for your model.

These warranties expressly exclude any defects or damages caused by accessories, replacement parts or repair service other than those that have been authorized by Cuisinart. These warranties exclude all incidental or consequential damages.

### BEFORE RETURNING YOUR CUISINART® PRODUCT

**Important:** If the nonconforming product is to be serviced by someone other than Cuisinart's Authorized Service Centre, please remind the servicer to call our Consumer Service Centre to ensure that the problem is properly diagnosed, the product serviced with the correct parts, and to ensure that the product is still under warranty.

# Cuisinart®

SAVOR THE GOOD LIFE®



Coffeemaker



Blender



Toaster Ovens



Food Processor

Cuisinart offers an extensive assortment of top quality products  
to make life in the kitchen easier than ever.

Try some of our other countertop appliances and cookware,  
and Savor the Good Life®.

**[www.cuisinart.ca](http://www.cuisinart.ca)**

©2006 Cuisinart  
Cuisinart® is a registered trademark of Cuisinart  
156 Parkshore Drive,  
Brampton, Ontario  
L6T 5M1

Consumer Call Centre E-mail:  
[Consumer\\_Canada@Conair.com](mailto:Consumer_Canada@Conair.com)

Printed in China  
05CC25040