

Cuisinart®



Brew Central Thermal™ Coffeemaker

DCC-1400C Series

For your safety and continued enjoyment of this product, always read the instruction book carefully before using.

IMPORTANT SAFEGUARDS

When using electrical appliances, basic safety precautions should always be followed to reduce the risk of fire, electric shock and/or injury to persons, including the following:

- 1. READ ALL INSTRUCTIONS**
2. Do not touch hot surfaces. Use handles and knobs.
3. To protect against electric shock, do not place cord, plug, or base unit in water or other liquids.
4. Close supervision is necessary when any appliance is used by or near children.
5. **Always unplug from outlet when not in use and before cleaning.** Allow to cool before putting on or taking off parts and before cleaning the appliance.
6. Do not operate any appliance with a damaged cord or plug or after the appliance malfunctions or has been dropped or damaged in any manner. Return appliance to the nearest Cuisinart Repair Centre for examination, repair, or electrical or mechanical adjustment.
7. The use of accessory attachments not recommended by Cuisinart may cause injuries.
8. Do not use outdoors.
9. Do not let cord hang over edge of table or counter, or touch hot surface.
10. Do not place on or near a hot gas or electric burner, or in a heated oven.
11. Always fill water reservoir first, then plug cord into the wall outlet. To disconnect, turn controls to “off”, then remove plug from wall outlet.
12. Do not use appliance for other than intended use.
13. Fasten lid securely onto carafe before serving any beverages.
14. Scalding may occur if the lid is removed during the brewing cycle.
15. The thermal carafe is designed for use with these appliances only. It must never be used on the range top.
16. Do not set a hot carafe on a wet or cold surface.
17. Do not use a cracked carafe or a carafe having a loose or weakened handle.
18. Do not clean carafe or warming plate with cleansers, steel wool pads, or other abrasive materials.
19. **WARNING: TO REDUCE THE RISK OF FIRE OR ELECTRIC SHOCK, DO NOT REMOVE THE BASE PANEL. NO USER SERVICEABLE PARTS ARE INSIDE. REPAIR SHOULD BE DONE ONLY BY AUTHORIZED PERSONNEL.**
20. Avoid contact with moving parts.

SAVE THESE INSTRUCTIONS

FOR HOUSEHOLD USE ONLY

WARNING: RISK OF FIRE OR ELECTRIC SHOCK



The lightning flash with arrowhead symbol, within an equilateral triangle, is intended to alert the user to the presence of uninsulated “dangerous voltage” within the product’s enclosure that may be of sufficient magnitude to constitute a risk of fire or electric shock to persons.



The exclamation point within an equilateral triangle is intended to alert the user to the presence of important operating and maintenance (servicing) instructions in the literature accompanying the appliance.

SPECIAL CORD SET INSTRUCTIONS

A short power-supply cord is provided to reduce the risks resulting from becoming entangled in or tripping over a longer cord.

Longer extension cords are available and may be used if care is exercised in their use.

If a long extension cord is used, the marked electrical rating of the extension cord must be at least as great as the electrical rating of the appliance, and the longer cord should be arranged so that it will not drape over the countertop or tabletop where it can be pulled on by children or tripped over.

NOTICE

This appliance has a polarized plug (one blade is wider than the other). To reduce the risk of electric shock, this plug will fit in a polarized outlet only one way. If the plug does not fit fully in the outlet, reverse the plug. If it still does not fit, contact a qualified electrician. Do not modify the plug in any way.

OPERATING NOTICE

Clogging and backing up of water and/or coffee in the filter basket can occur under any or a combination of any of the following conditions: The use of too finely ground coffee, using two or more paper filters, using the gold tone filter in conjunction with a paper filter or not properly cleaning coffee grounds from the gold tone filter, or allowing coffee grounds to spill over the filter.

Caution: Never open the top cover during the brewing cycle, even if no water is draining from the filter basket, since extremely hot water/coffee can spill out from the filter basket and cause injury. If water/coffee is not draining from the filter basket during the brewing cycle, unplug the unit and wait 10 minutes before opening the top cover and checking the filter basket.

IMPORTANT UNPACKING INSTRUCTIONS

1. Place the box on a large, sturdy, flat surface.
2. Remove the instruction book and any other literature.
3. Turn the box so that the back side of the coffeemaker is down and slide the coffeemaker from the box.
4. After the coffeemaker has been removed, place the box out of the way and lift off the top two polyfoam inserts.
5. Remove the cardboard insert between the carafe lid and Brew Pause™ mechanism by sliding it out of the unit.
6. Grasp the carafe by its handle, remove it from the resting plate, and remove the polybag.
7. Lift the coffeemaker off the remaining two inserts and remove the polybag covering the coffeemaker.

We suggest you save all packing materials in the event that future shipping of the machine is needed. Keep all plastic bags away from children.



TABLE OF CONTENTS

Important Safeguards	Page 1
Unpacking Instructions	Page 2
Introduction	Page 3
The Quest for the Perfect Cup of Coffee	Page 3
Features and Benefits	Page 4
Control Panel	Page 5
Programming Your Coffeemaker	Page 6
Setting the Time	Page 6
Programming the Auto On	Page 6
Making Coffee	Page 7
Inserting the Water Filter	Page 7
Cleaning and Maintenance	Page 8
Warranty	Page 9

INTRODUCTION

Cuisinart introduces a coffeemaker with retro styling and the latest high tech features, making it the centerpiece of any kitchen. The Cuisinart® Brew Central Thermal™ Coffeemaker is reminiscent of the days of classic styling and durable materials. A brushed stainless steel exterior with retro-style controls houses the finest coffeemaking technology. This coffeemaker even includes a charcoal water filter. The water filter ensures great tasting coffee by removing all of the impurities from the water. Coffee brews through and pours through a self-sealing lid into a double-wall insulated thermal carafe to keep it fresh and hot for hours. The Brew Central Thermal™ Coffeemaker also comes with advanced features such as a programmable digital clock with 24-hour advanced-brew setting, an automatic shutoff, a self-cleaning function, and an audible beep option that signals the end of the brew cycle, which makes brewing the best tasting coffee easy.

THE QUEST FOR THE PERFECT CUP OF COFFEE

It is generally agreed that there are four basic elements critical to the perfect cup:

Element 1: Water

Coffee is 98% water. Often overlooked, the quality of the water is as important as the quality of the coffee. A good rule of thumb is that if your water doesn't taste good from the tap, it won't taste any better in your coffee. That's why Cuisinart has added a water filter to the Brew Central Thermal™ Coffeemaker. The

charcoal water filter removes chlorine, calcium and bad tastes and odours, for the purest cup of coffee every time.

Element 2: Coffee

While the bulk of the liquid is water, all of the flavour should be from the coffee. To achieve the same great quality cup of coffee you receive at a coffee bar, you need to use the same quality beans. If you choose to grind your own beans, buy the beans fresh and whole, only about a two week supply at a time for maximum freshness. Once the coffee bean is broken, its flavour degrades very quickly. If it is not practical to buy small supplies, we recommend you separate larger amounts of beans into one to two week portions immediately after purchasing, and freeze them in airtight containers. The best way to maximize freshness is to minimize exposure to air, light and moisture. So, once removed from the freezer, beans should be maintained in a sealed container at room temperature, since damaging condensation occurs every time the beans are removed from the freezer or refrigerator. Note that some coffee experts advise against freezing dark-roast beans because this can cause the oils to coagulate, while other experts disagree. We suggest you experiment and decide for yourself.

Element 3: Grind

The grind is critical for proper flavour extraction. If the grind is too fine, overextraction and bitterness will result. Too fine a grind may also clog your filter. If grind is too coarse, the water will pass through too quickly and the desired flavours will not be extracted. We recommend a medium-fine grind.

Element 4: Proportion

The cups on the Cuisinart® coffeemaker are 5 ounces (148 ml). Add the amount of ground coffee that corresponds to the number of cups being brewed. Many coffee bars and the Specialty Coffee Association of America recommend adding 2 rounded tablespoons (30 ml) of coffee per 6 ounces (170 ml) of water. Some coffee manufacturers recommend using one tablespoon (15 ml) per cup. We recommend using 1 tablespoon (15 ml) of ground coffee per cup, but use more or less to suit your taste.

NOTE: The maximum capacity for ground coffee is 15 tablespoons for this 10-cup (1.5 L) coffeemaker. Exceeding this amount may cause overflow if the coffee is too finely ground.

FEATURES AND BENEFITS

- 1. Reservoir Cover**
Flips back for easy filling.
- 2. Water Reservoir**
- 3. Showerhead (not shown)**
Distributes water evenly over coffee, reducing temperature loss as water passes through grounds.
- 4. Water Filter (not shown)**
Charcoal water filter eliminates chlorine, calcium and bad tastes and odours from tap water.
- 5. Filter Basket (not shown)**
Holds a #4 paper filter or a permanent filter.
- 6. Filter Basket Holder**
- 7. LCD Digital Clock**
Displays time of day and set time for automatic functions.
- 8. Hour and Minute Buttons**
Used to set time of day and automatic functions.
- 9. Function Knob**
Used to initiate programming of automatic functions.
 - a. Ready Tone**
Signals the end of the brew cycle with five beeps. Choose "ON" for audible signal or "OFF" to turn signal off.
 - b. 1-4 Cup Setting**
For brewing smaller pots of coffee. It provides 'double' heating of the water, so coffee is piping hot.
 - c. Self-Clean Setting**
Tells you when it's time to clean your coffeemaker. Remove built-up calcification from the water reservoir, to help extend the life of your coffeemaker.
- 10. Brew Pause™**
Stops flow of coffee from basket when carafe is removed (30 seconds max) from the heater plate, so a cup can be poured in mid-brew. Since the extraction rate varies during the brew cycle, we recommend allowing the brewing cycle to finish before pouring the coffee.

11. Thermal Carafe with Hands-Free Lid

An easy pour, no drip double-wall insulated 10-cup stainless steel thermal.

Coffee brews through and pours through a unique lid that seals air out to provide fresh flavour. No need to turn or adjust lid.

12. Resting Plate

Scratch resistant with black, nonstick coating.

13. Cord Storage (not shown)

14. Measuring Scoop (not shown)

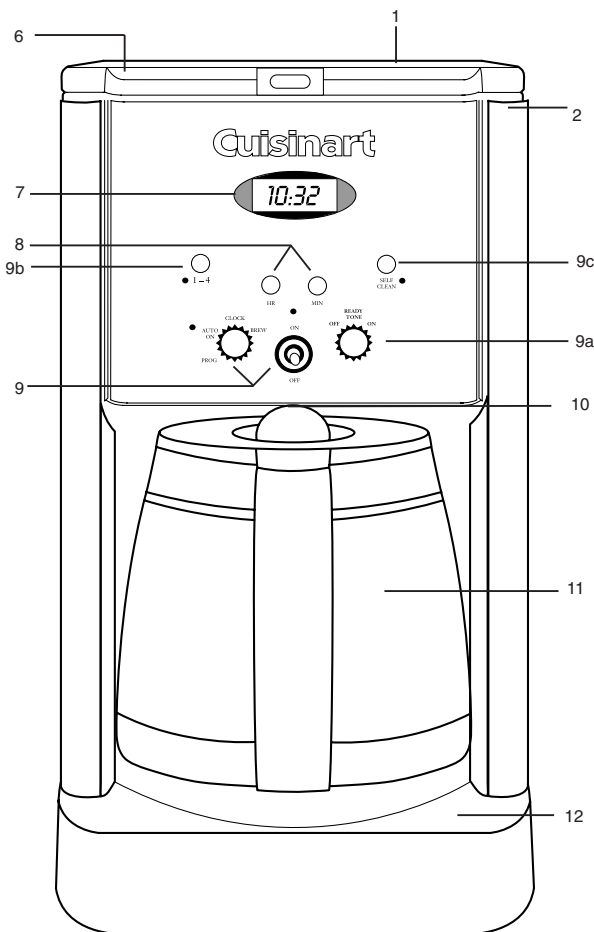

CONTROL PANEL

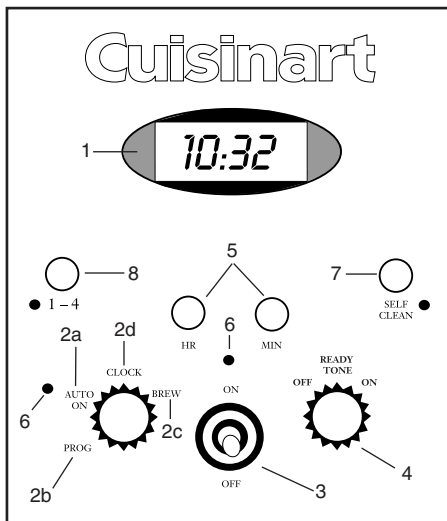

1. Clock Display

Displays time of day and auto on and off times.

2. Function Knob

For setting time of day, and auto on and auto off times.

a. Auto On

The Auto On feature is used to program the start time of the brew cycle. The auto on time can be set for any time, day or night. The "PM" indicator is displayed on the LCD for nighttime program times.

b. Program Set

The Program Set function is used to set the time for the Auto On function.

c. Brew

The Brew function is used to start the brew cycle directly.

d. Clock Set

Used to program the time of day.

3. Flip Switch

Retro-style flip switch is used to turn your coffeemaker on and off and works in tandem with the function knob.

4. Ready Tone Control Knob

The Brew Central Thermal™ Coffeemaker is equipped with an audible tone which will sound 5 times when the coffee has completed brewing (coffee will continue to stream from the filter for a few seconds after tone).

Choose "ON" for audible signal or choose "OFF" to turn audible signal off.

5. Hour and Minute Buttons

For use in setting hour and minute for time of day and auto on time.

6. On and Auto On Indicator Lights

7. Self Clean Setting

Used for removing calcium buildup.

8. 1-4 Cup Setting

For brewing smaller pots of coffee – it provides 'double' heating of the water, so coffee is piping hot.

PROGRAMMING YOUR COFFEEMAKER

TO BREW COFFEE

1. Turn the FUNCTION KNOB to the “Brew” position.
2. Lift the FLIP SWITCH up to the “On” position and release. The red “On” indicator light will illuminate and brew cycle will begin.

TO TURN THE COFFEEMAKER OFF

Simply press the FLIP SWITCH down to the “Off” position and release.

PROGRAMMING YOUR COFFEEMAKER FOR DELAYED BREW TIME

To set the Time:

1. Turn the FUNCTION KNOB to “Clock”.
 - a. **Hours:** Press and hold the “Hour” button to scroll through numbers quickly. When number displayed approaches the desired setting, press and release (pulse) the button to advance one digit at a time. After setting the correct hour, the default will be the last time set unless power is shut off.

Note: When the number count passes 12, the PM light will be displayed on the LCD.

- b. **Minutes:** Press and hold the “Minute” button to scroll through numbers quickly. When number displayed approaches the desired setting, press and release (pulse) the button to advance one digit at a time. After setting the correct minute, the default will be the last time set unless power is shut off. To finish setting time, turn the FUNCTION KNOB to any other setting or simply wait until the numerals stop blinking.

To program the Auto On

1. Set the desired Brew-Start time.
 - a. Turn the FUNCTION KNOB to “Prog”.
 - b. Set the time you want coffee to begin brewing by using the minute and hour push buttons. Follow the same instructions you used to set the time of day, in the **To set the time** section above.
2. Turn the FUNCTION knob to the “Auto On”

position. LCD will display the current time.

3. Lift and release the FLIP SWITCH. The green indicator light will come on to remind you that the programming function is in use. At the programmed time, the red light will come on as well, indicating that the brew cycle is starting. Both lights will go off when brew cycle ends.

NOTE: To reactivate the auto-on feature to start brew cycle at the same time another day, simply lift and release the FLIP SWITCH. The green “auto-on” light will illuminate.

Decalcification:

Decalcification refers to the removal of calcium deposits which form over time on the metal parts of the coffeemaker.

For best performance from your Brew Central Thermal™ Coffeemaker, decalcify the base unit from time to time. The frequency depends upon the hardness of your tap water and how often you use the coffeemaker. The flashing Self Clean light will indicate when you should clean your coffeemaker.

Self Cleaning:

If the Self Clean light begins to flash when the coffeemaker is turned on, it is telling you that the calcium buildup is interfering with the functioning of your coffeemaker and the flavour of your coffee. To clean, fill the water reservoir to capacity with a mixture of 1/3 white vinegar and 2/3 water. Press the Self Clean button. When the self clean light glows, turn the coffeemaker on by pressing the flip switch to ON. The Self Clean light will shine steadily. The coffeemaker is now in Self Clean mode. One cycle should be sufficient to adequately clean the coffeemaker. When the cycle is completed and the five beeps sound, the coffeemaker will shut off. Turn the coffeemaker ON to see if the Self Clean light continues to flash. If it does, turn it to OFF and then repeat the cleaning procedure with a fresh solution of vinegar and water.

If the Self Clean light no longer flashes, turn the coffeemaker to OFF and then run one cycle of fresh cold water through the unit before using the unit again to brew coffee.

Notes on the Self Clean Function

Pressing the Self Clean button cancels all other settings. If it is pressed accidentally,

press it again to return the coffeemaker to all its previous settings. Pressing ON/OFF will also exit the Self Clean Mode and turn the coffeemaker OFF.

1-4 Cup Setting:

The 1-4 cup setting button is used when you make small amounts of coffee. Normal coffeemakers will produce a colder batch of coffee when smaller amounts are made, because the heater doesn't have enough time to properly 'warm up' to heat a small amount.

The 1-4 setting basically 'double heats' the water, making your smaller amount as piping hot as a full pot would be.

To use: When making a smaller amount, press the 1-4 button on the control panel after turning on the unit.

Ready Tone Control:

The Brew Central Thermal™ Coffeemaker is equipped with an audible tone which will sound 5 times when the coffee has completed brewing (coffee will continue to stream from the filter for a few seconds after tone).

Choose "ON" for audible signal or choose "OFF" to turn audible signal off.

MAKING COFFEE

Before you make the first pot of coffee in your new Cuisinart® Brew Central Thermal™ Coffeemaker, we recommend operating the coffeemaker once using only water and a paper filter. This will remove any dust or residues that remain in the system from the manufacturing process.

1. Insert the Water Filter:

- Remove the filter from polybag and soak in cold tap water for 15 minutes.
- Remove the water filter holder from the coffeemaker by lifting it out of the reservoir area with your thumb and forefinger.
- Grasp stem in one hand. Using thumb of other hand, gently press down and pull toward you. Compartment will flip open.

- Place the filter in the holder and close the water filter holder; you will hear a snap indicating it is in place.

NOTE: Caution must be used when inserting the charcoal filter. Improper placement in the holder can cause tearing of the filter skin.

- Hold the filter under cold running tap water for 10 seconds to flush. You should place the hole openings in the side of the unit directly under the water stream.
- Allow the filter to drain completely.
- Replace the water filter holder in the reservoir area of the coffeemaker, pushing it all the way down to the base of the unit, along the reservoir wall.

Note: We recommend changing the water filter every 60 days or 60 uses – more often if you have hard water.

Replacement water filters can be purchased in stores or by calling customer service or through the Cuisinart web site.

2. Fill the water reservoir:

When filling the coffeemaker with water, refer to the reservoir height markings and fill to the desired number of cups.

3. Add the ground coffee:

Remove the filter basket by grasping the handle and lifting straight up, and then place it on the countertop. Insert a #4 paper filter

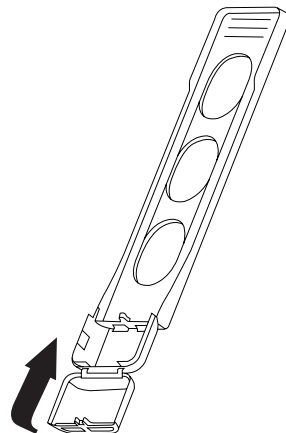

or permanent filter. Be sure that the paper filter is completely open and fully inserted in the basket. It may help to fold and flatten the seams of a paper filter beforehand. Add the desired amount of ground coffee, corresponding to the number of cups being brewed. Many coffee bars and the Specialty Coffee Association of America recommend adding 2 rounded tablespoons (30 ml) of coffee per 6 ounces (170 ml) of water. Some coffee manufacturers recommend using 1 tablespoon (15 ml) per cup. We recommend using 1 tablespoon (15 ml) of ground coffee per cup, but use more or less to suit your taste.

NOTE: The maximum capacity for ground coffee is 15 tablespoons (225 ml) for this 10 cup (1.5 L) coffeemaker. Exceeding this amount may cause overflow if the coffee is too finely ground.

Replace the filter basket in the filter basket holder and flip the water reservoir lid closed. Press firmly on top where it says "Press to Close". Be sure that it closes securely in place.

Before brewing coffee:

Remove thermal carafe lid by turning in the direction of the "unlock" arrow. Prewarm carafe by rinsing it out with hot water. **PREWARMING THE CARAFE WILL HELP KEEP THE COFFEE HOTTER.**

Return the carafe lid to the carafe. To lock the lid, turn in the direction of the "lock" arrow until it fits tightly on carafe and arrow lines up in the centre of the pour spout. This ensures lid is closed and in the proper position for brewing and pouring.

Make sure you have replaced the carafe in its position on the heating plate and have closed the top cover. Plug the cord into an electrical outlet.

4. Power unit:

Turn the function knob to brew, lift flip switch up to "On" position, and the red indicator light will turn on. Or, set the Auto On function and the green indicator will light.

5. During and after brewing:

The Brew Pause™ feature allows you to remove the carafe from the plate during mid-brew. The brewing process does not

stop during this period – only the flow of coffee from the basket stops. Do not remove the carafe for longer than 30 seconds or the coffee may overflow the basket. While we offer this feature, we do not recommend that you pour the coffee before the cycle has reached completion, since the coffee brewed at the beginning of the cycle has a flavour profile which is very different from the flavour at the end of the cycle. Removing a cup during the brewing cycle will alter the flavour of the finished pot.

Once the coffee has finished brewing, stir it before serving to blend the flavours. The coffee at the bottom of the carafe will be somewhat stronger than the coffee at the top.

When the brewing cycle has been completed, five beeps will sound unless you have turned off the ready tone. Coffee will continue to stream from the filter for several seconds.

After brewing, the unit will automatically shut itself off. The thermal carafe will keep the coffee hot for hours.

Bottom of Thermal Carafe is hot to touch for several minutes after brewing. Use caution.

The brew-through, pour-through lid allows coffee to drip from coffeemaker through the closed lid. When brewing is complete, the lid seals itself so air stays out and coffee freshness and temperature are preserved. No need to turn or adjust the lid before pouring.

CLEANING AND MAINTENANCE

Always turn coffeemaker OFF and remove the plug from the electrical outlet before cleaning.

Lift up the reservoir cover. Remove and discard the paper filter and ground coffee. The filter basket and gold tone filter can be washed in warm, soapy water and rinsed thoroughly, or cleaned in the upper rack of the dishwasher. Dry all parts after use.

Do not put any water in the unit once the filter basket has been removed. Wipe the area under the filter basket with a damp cloth.

Remove the carafe from the resting plate. Discard any remaining coffee. The carafe and lid can be washed in warm, soapy water and rinsed thoroughly, or placed in a dishwasher. The carafe and carafe lid should be placed on the upper rack only.

Do not use any scouring agents or harsh cleansers on any part of the coffeemaker.

Never immerse base unit in water or other liquid. To clean base, simply wipe with a clean, damp cloth and dry before storing. Fingerprints and other blemishes on the stainless steel housing can be washed off with soap and water or a nonabrasive cleaning solution. Wipe resting plate with a clean, damp cloth. Never use rough, abrasive materials or cleansers to clean the resting plate. Do not dry the inside of the water reservoir with a cloth, as lint may remain.

WARRANTY

LIMITED THREE-YEAR WARRANTY

This warranty supersedes all previous warranties on the Cuisinart® Brew Central Thermal™ Coffeemaker. This warranty is available to consumers only. You are a consumer if you own a Cuisinart® Brew Central Thermal™ Coffeemaker that was purchased at retail for personal, family or household use. This warranty is not available to retailers or other commercial purchasers or owners.

We warrant that your Cuisinart® Brew Central Thermal™ Coffeemaker will be free of defects in material or workmanship under normal home use for three years from the date of original purchase.

For warranty purposes, we would like to suggest that you register your product on-line at www.cuisinart.ca to facilitate verification of the date of original purchase. However, should you not wish to register on-line we recommend the consumer to maintain original receipt indicating proof of purchase. In the event that you do not have proof of purchase date, the purchase date for purposes of this warranty will be the date of manufacture.

When calling our Authorized Service Centre for in warranty service please make reference to your model number and the manufacturing

date code. This information can be found in the rating area on the body or underneath the base of your unit. The model number will follow the word Model: DCC-1400C. The manufacturing date code is a 4 or 5 digit number sometimes followed by a letter. Example, 40630K would designate year, month & day (2004, June 30th).

If your coffeemaker should prove to be defective within the warranty period, we will repair it or, if we think it necessary, replace it. To obtain warranty service, please call our Consumer Service Centre toll-free at 1-800-472-7606 or write to:

Cuisinart Canada
156 Parkshore Drive
Brampton, Ont. L6T 5M1

To facilitate the speed and accuracy of your return, please also enclose \$10.00 for shipping and handling of the product. Please also be sure to include a return address, description of the product defect, product serial number, and any other information pertinent to the product's return. Please pay by cheque or money order.

NOTE: For added protection and secure handling of any Cuisinart® product that is being returned, we recommend you use a traceable, insured delivery service.

Cuisinart cannot be held responsible for in transit damage or for packages that are not delivered to us. Lost and/or damaged products are not covered under warranty.

Your Cuisinart® coffeemaker has been manufactured to strict specifications and has been designed for use with the Cuisinart® coffeemaker authorized accessories and replacement parts for your model.

These warranties expressly exclude any defects or damages caused by accessories, replacement parts or repair service other than those that have been authorized by Cuisinart. These warranties exclude all incidental or consequential damages.

BEFORE RETURNING YOUR CUISINART PRODUCT

Important: If the nonconforming product is to be serviced by someone other than

Cuisinart's Authorized Service Centre, please remind the servicer to call our Consumer Service Centre to ensure that the problem is properly diagnosed, the product serviced with the correct parts, and to ensure that the product is still under warranty.

Cuisinart®

SAVOR THE GOOD LIFE®



Coffeemakers



Food Processors



Toaster Ovens



Blenders



Cookware



Ice Cream Makers

Cuisinart offers an extensive assortment of top quality products to make life in the kitchen easier than ever. Try some of our other countertop appliances and cookware, and Savor the Good Life®.

www.cuisinart.ca

©2005 Cuisinart

Cuisinart® is a registered trademark of Cuisinart

156 Parkshore Dr.
Brampton, Ont. L6T 5M1

Consumer Call Centre E-mail:
Consumer_Canada@Conair.com

Printed in China

05CC25005

IB-5255-CAN